

# **PROCHEM**®

## **BLAZER GT**

MOBILE CLEANING UNIT

Operating Instructions (ENG)

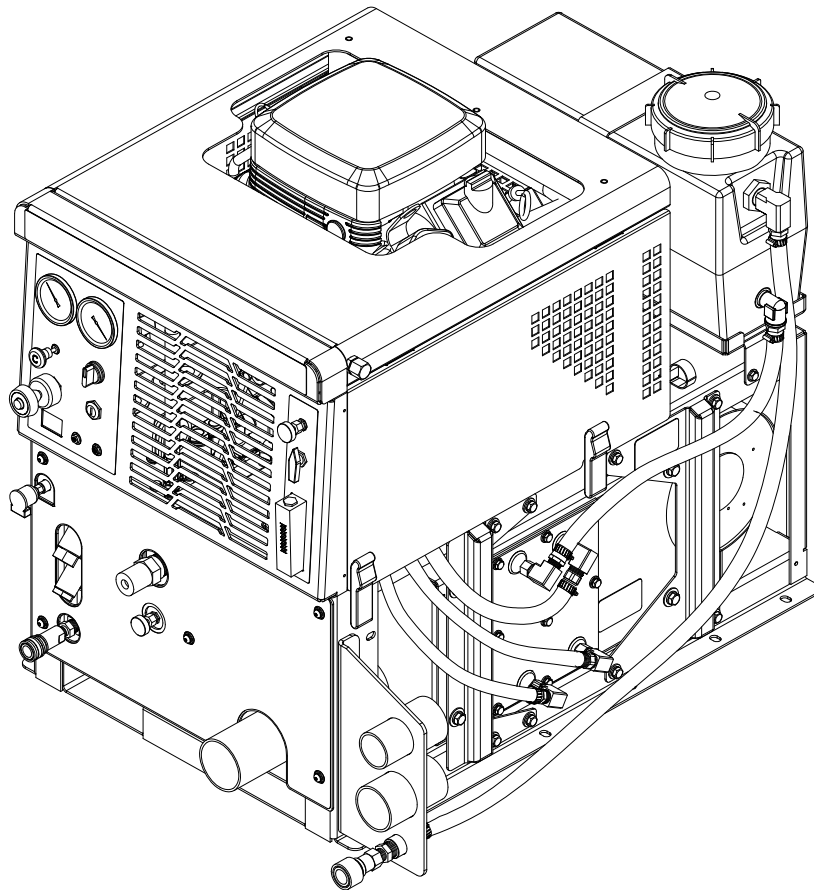

MODELS: BLAZER GT  
1.001-121.0

---

*Read instructions before operating the machine.*

86317260 - B  
07/30/09

Left intentionally blank

Model: \_\_\_\_\_  
Date of Purchase: \_\_\_\_\_  
Serial Number: \_\_\_\_\_  
Dealer: \_\_\_\_\_  
Address: \_\_\_\_\_  
Phone Number: \_\_\_\_\_  
Sales Representative: \_\_\_\_\_

**Welcome**...and congratulations on the purchase of your Mobile Cleaning Unit. This instruction manual is a guide for operating and servicing your unit. **Read this manual completely before installing or operating this unit.** This unit offers you personal convenience. All of your instrumentation and controls have been positioned to give you easy access for operation and daily maintenance.

Proper operation and service are essential to the efficient functioning of this unit. When maintained correctly, this unit will have a long, trouble-free life.

The service methods described in this manual are explained in such a manner that servicing may be performed accurately and safely. Proper service varies with the choice of procedure, the skill of the mechanic, and the tools or parts available. Before attempting any repair, make certain that you are thoroughly familiar with this equipment and are equipped with the proper tools. Any questions pertaining to operating or servicing this unit should be directed to your nearest dealer.

**THIS UNIT MUST BE INSTALLED BY THE DEALER FROM WHOM YOU PURCHASED IT IN ACCORDANCE WITH THE PRESCRIBED INSTALLATION PROCEDURES.**

**MAKE CERTAIN THAT THE WARRANTY CARD IS FILLED OUT AT THE TIME OF INSTALLATION AND IS RETURNED TO YOUR DEALER.**

PROFESSIONAL CHEMICALS CORPORATION  
325 SOUTH PRICE ROAD  
CHANDLER, ARIZONA 85224

Information in this document is subject to change without notice and does not represent a commitment on the part of Professional Chemicals Corporation.

## Table of Contents

<b>Machine Data Log / Overview</b> .....	<b>1</b>
<b>Table of Contents</b> .....	<b>2</b>
<b>Receiving Your Unit</b> .....	<b>4</b>
Dealer Responsibility .....	4
Acceptance of Shipment .....	4
Equipment List .....	4
<b>How to Use This Manual</b> .....	<b>5</b>

### Safety

<b>IMPORTANT SAFETY INSTRUCTIONS</b> .....	<b>6</b>
Safety Labels .....	8

### Operations

Technical Specifications .....	9
Installation Requirements .....	10
Fuel Requirements .....	10
Engine Oil Requirements .....	10
Altitude Requirements .....	10
Chemical Requirements .....	11
Water Requirements .....	11
Components .....	12
Vacuum System .....	15
Water Pumping and Heat Transfer System .....	16
Heat Exchanger .....	16
Chemical Injection System .....	18
Pre-Run Inspection .....	19
Check For Adequate Fuel .....	19
Remove Tools From Vehicle .....	19
Water Supply Connection .....	19
High Pressure Hose .....	19
Vacuum Hose .....	19
Filters .....	19
Priming the Chemical Pump .....	20
Waste Pump (Optional) .....	20
Cleaning .....	20
Upholstery Cleaning .....	21
Shutdown and Daily Maintenance .....	21
Freezing Protection .....	21
Overheating Protection .....	21
Winterizing the Unit .....	22
Removing Anti-Freeze From the Unit .....	23

### Maintenance

Service Schedule .....	24
Key Checkpoints .....	26
External Fuel Pump Maintenance .....	26
Chemical Supply System Maintenance .....	26
Heat Exchanger System Maintenance .....	26
Engine .....	27
Vacuum Pump Maintenance .....	27
Vacuum Pump .....	28
Water Pump .....	29
Vacuum Inlet Filter (in Waste Tank) .....	29
Vacuum Relief Valve .....	29
Vacuum Pump Drive Belts .....	29
Water Pump Drive Belts .....	30
Float Valve (Water Box) .....	30
Waste Tank Float Valve .....	30
Waste Tank Strainer Basket .....	30
Waste Tank Vacuum Inlet Filter .....	30
Solution Outlet Screen .....	30
Check Valve (Outlet) .....	31
Chemical Pump .....	31
Chemical and Heat Bypass Valves .....	31
Pressure Regulator .....	31
Vacuum Hoses .....	31
High Pressure Hoses .....	31
Optional Waste Pump-Out .....	31
<b>Service General Adjustments</b> .....	<b>32</b>
Engine Speed .....	32
Check Valve (Solution Outlet) .....	32
Water Box .....	32
Chemical Pump .....	32
Water and Vacuum Pump Drive Belts .....	32
Chemical Metering Bypass and Chemical Selector Valves .....	33
Pressure Regulator .....	33
<b>Troubleshooting</b> .....	<b>34</b>

**PARTS**

Frame . . . . .	40
Side Panel. . . . .	42
Control Panel . . . . .	44
Engine. . . . .	48
Vacuum Pump . . . . .	50
Solution Pump. . . . .	52
Water Pump . . . . .	54
Heat Exchanger . . . . .	56
Pressure Regulator & Temperature Control Valve	58
Solution Outlet . . . . .	60
Water Box. . . . .	62
60 Gallon Waste Tank . . . . .	64
100 Gallon Waste Tank . . . . .	66
Hose Accessories . . . . .	68
Battery Floor Mount . . . . .	70
Exhaust-Optional . . . . .	72
Automatic Pumpout - Optional . . . . .	74
Wand - Titanium Six Jet - Optional . . . . .	78
Wand - Ergo Titanium Six Jet - Optional. . . . .	80
Wand - Quad Jet - Optional . . . . .	82
Wand - Tri Jet -Optional . . . . .	84
Stair Tool - Optional . . . . .	86
Upholstery Tool - Optional . . . . .	88
Shelf Assembly - Optional. . . . .	90
Auxiliary Water Tank with Pump - Optional . . . . .	92
Water Tank Dual with Demand Pump - Optional .	94
Water Tank - Demand Pump - Optional . . . . .	96
Auxiliary Water Tank - Optional . . . . .	98
Hose Reel - Optional. . . . .	100
Hose Diagram. . . . .	102
Wiring Diagram . . . . .	103

### Dealer Responsibility

The dealer from whom you purchased this mobile cleaning unit is responsible for the correct installation of this machine. The dealer is also responsible for initial training of your operators and maintenance personnel in the proper operation and maintenance of this unit.

### Acceptance of Shipment

Every part of your cleaning unit was carefully checked, tested, and inspected before it left our manufacturing plant. **Upon receiving the unit, make the following acceptance check:**

1. The unit should not show any outward signs of damage. If damaged, notify the common carrier immediately.
2. Check your equipment and packing list. The standard cleaning unit should arrive equipped with the following items (unless otherwise specified) and any optional accessories which were ordered:

### Equipment List

- Console.
- Operation and service manual with engine, water pump, and vacuum pump manuals.
- Installation bolting kit.
- Installation mounting plates.
- Hose clamps for fuel & vacuum hoses.
- Carpet wand.
- Waste tank w/float switch.
- Waste tank filter and strainer basket.
- 100 ft. of 2" vacuum hose.
- 1 vacuum hose connector.
- 100 ft. of 1/4" high pressure hose with quick connects.
- 50 ft. water supply hose with quick connect.
- 5 gallon jug and holder.

Each unit will require a fuel system installation kit that is purchased separately from the unit .

This manual contains the following sections:

- How to Use This Manual
- Safety
- Operations
- Maintenance & Service
- Parts List

The HOW TO USE THIS MANUAL section will tell you how to find important information for ordering correct repair parts.

Parts may be ordered from authorized dealers. When placing an order for parts, the machine model and machine serial number are important. Refer to the MACHINE DATA box which is filled out during the installation of your machine. The MACHINE DATA box is located on the inside of the front cover of this manual.

Model: \_\_\_\_\_

Date of Purchase: \_\_\_\_\_

Serial Number: \_\_\_\_\_

Dealer: \_\_\_\_\_

Address: \_\_\_\_\_

Phone Number: \_\_\_\_\_

Sales Representative: \_\_\_\_\_

The model and serial number of your machine is located approximately where shown.

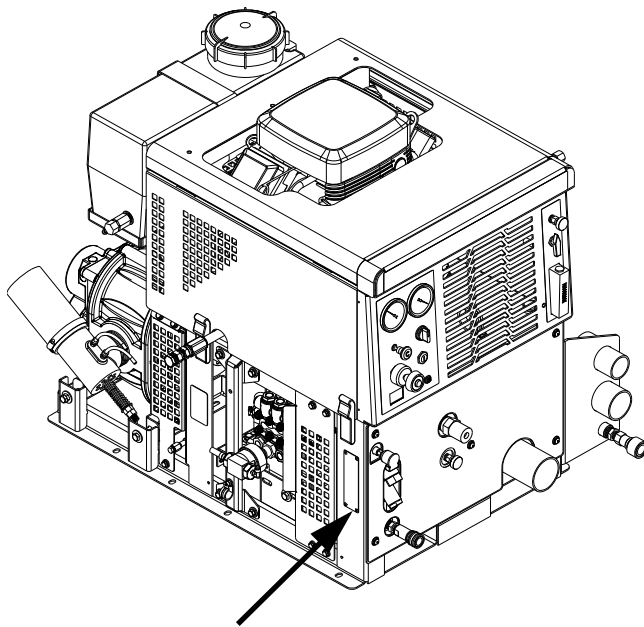

The SAFETY section contains important information regarding hazardous or unsafe practices of the machine. Levels of hazards are identified that could result in product damage, personal injury, or severe injury resulting in death.

The OPERATIONS section is to familiarize the operator with the operation and function of the machine.

The MAINTENANCE section contains preventive maintenance to keep the machine and its components in good working condition. They are listed in this general order:

- Engine
- Vacuum Pump
- Drive Belts, Pulleys & Hubs
- Chemical Pump
- Hoses
- Exhaust Heat Exchanger
- General Service Adjustments
- Machine Troubleshooting

The PARTS LIST section contains assembled parts illustrations and corresponding parts list. The parts lists include a number of columns of information:

- **REF** – column refers to the reference number on the parts illustration.
- **PART NO.** – column lists the part number for the part.
- **PRV NO.** – reference number.
- **QTY** – column lists the quantity of the part used in that area of the machine.
- **DESCRIPTION** – column is a brief description of the part.
- **SERIAL NO. FROM** – If this column has an (\*) and a Reference number, see the SERIAL NUMBERS page in the back of your manual. If column has two asterisk (\*\*), call manufacturer for serial number. The serial number indicates the first machine the part number is applicable to. The main illustration shows the most current design of the machine. When a boxed illustration is shown, it displays the older design.
- **NOTES** – column for information not noted by the other columns.

**NOTE:** If a service or option kit is installed on your machine, be sure to keep the KIT INSTRUCTIONS which came with the kit. It contains replacement parts numbers needed for ordering future parts.

**NOTE:** The manual part number is located on the lower left corner of the front cover.

# IMPORTANT SAFETY INSTRUCTIONS

When using this machine, basic precaution  
must always be followed, including the following:

**READ ALL INSTRUCTIONS BEFORE USING THIS MACHINE.**



These symbols mean **WARNING** or **CAUTION**. Failure to follow warnings and cautions could result in fatality, personal injury to yourself and/or others, or property damage. Follow these instructions carefully!



**Read the operator's manual before installing or starting this unit.** Failure to adhere to instructions could result in severe personal injury or could be fatal.

**Operate this unit and equipment only in a well-ventilated area.** Exhaust fumes contain carbon monoxide which is an odorless and deadly poison that can cause severe injury or fatality. **DO NOT** run this unit in an enclosed area. **DO NOT** operate this unit where the exhaust may enter any building doorway, window, vent, or opening of any type.

**Gasoline is extremely flammable and its vapors can explode if ignited.** Store gasoline only in approved containers, in well-ventilated, unoccupied buildings away from sparks or flames. Never carry any gasoline or flammable material in the vehicle. Fumes may accumulate inside the vehicle and ignite, causing an explosion.

**DO NOT** store any type of flammable material in the vehicle.

This unit must be operated with the vehicle or trailer doors open in order to ensure adequate engine ventilation.

**DO NOT operate engine if gasoline is spilled.** Avoid creating any ignition until the gasoline has been cleaned up. Never use gasoline as a cleaning agent.

**DO NOT place hands, feet, hair, or clothing near rotating or moving parts.** Avoid any contact with moving parts! Rotating machinery can cause injury or fatality.

**Never operate this unit without belt guards.** The high speed moving parts, such as belts and pulleys, should be avoided while this unit is running. Severe injury, damage, or fatality may result.

**DO NOT service this unit while it is running.** The high-speed mechanical parts as well as high temperature components may result in severe injury or severed limbs.

**Never touch electrical wires or components while the engine is running.** They can be sources of electrical shock.

**Engine components can get extremely hot from operation.** To prevent severe burns, **DO NOT** touch these areas while the engine is running or immediately after the engine is turned off.

**DO NOT touch any part of the exhaust system while this unit is running.** Severe burns may result.

**Before servicing this unit, allow it to "cool down."** This will prevent burns from occurring.

**Water under high pressure at high temperature can cause burns, severe personal injury, or fatality. Shut down machine, allow to cool down, and relieve system of all pressure before removing valves, caps, plugs, fittings, filters, and bolts.**

**Always wear hearing protection when unit is running. Always comply with your company's Personal Protection Equipment (PPE) plan. Always comply with local noise ordinance when operating units.**



**DO NOT leave the vehicle engine running while operating this unit.**

**Dangerous Acid, Explosive Gases!** Batteries contain sulfuric acid. To prevent acid burns, avoid contact with skin, eyes and clothing. Batteries produce explosive hydrogen gas while being charged. To prevent a fire or explosion, charge batteries only in well ventilated areas. Keep sparks, open flames, and other sources of ignition away from the battery at all times. Keep batteries out of the reach of children. Remove all jewelry when servicing batteries.

Before disconnecting the negative (-) ground cable, make sure all switches are OFF. If ON, a spark will occur at the ground cable terminal which could cause an explosion if hydrogen gas or gasoline vapors are present. When disconnecting the battery, **ALWAYS** disconnect the negative (-) terminal **FIRST**.

**DO NOT smoke around the unit.** Gas fumes may accumulate and be ignited. The battery is also extremely flammable. This will prevent possible explosions.

**DO NOT damage the vehicle in any manner during installation.** When routing fuel lines **DO NOT** place the hose in any location where damage may occur to the hose or vehicle. Avoid any contact with moving parts, areas of high temperature, brake lines, fuel lines, muffler, catalytic converter, or sharp objects.

There is no fuel solenoid shut off on this unit. Use only the provided CARB approved fuel hose for fuel lines. When traversing the vehicle floor with fuel lines, always use a bulkhead adapter. This will prevent leakage and ensure that the hose is not punctured by vehicle vibration abrasion.

**Use only ProChem supplied fuel installation kits.** Ensure to use the kit specific for the truckmount model and van model being used. When traversing the vehicle floor with fuel lines, always use a bulkhead adapter. This will prevent leakage and ensure that the hose is not punctured by vehicle vibration abrasion.

**DO NOT exceed your vehicle's weight limit.** The console with empty waste tank and accessories weighs approximately 710 lbs (800 lbs. if mounted on water tank). Make certain to account for any additional accessories in your weight and balance calculations. Make certain that the vehicle has the correct axle rating. This will prevent unsafe vehicle driving conditions.

**We require high-back seats on all vehicles in which units are to be installed for head and neck protection.** We recommend using a metal partition between the seats and equipment.

**DO NOT operate this unit without the water supply attached and turned on.** The water pump and other vital components may be seriously damaged if this unit is permitted to operate dry without water.

**Keep your vehicle work area clean.** Wands, stair tools, and other accessories must be securely fastened before driving the vehicle.

**All high pressure hoses must be rated for 3000 PSI at 250°F.** Thermoplastic hoses do not meet these specifications and should not be used. Severe burns and injury may result if the hoses do not meet these requirements.

**The winterizing loop hose assembly, Part #86260700, PRV NO. 10-805380, is for winterizing use only.** If used improperly, live steam may escape from this hose, causing it to whip around. Burns or injury may result.

Make certain that you receive complete training by the distributor from whom you purchased this unit.

This unit uses high pressure and temperature. Improper or irresponsible use may result in serious injury.

**Do not modify this unit in any manner.** Improper modification can cause severe personal injury or fatality.

**CALIFORNIA PROPOSITION 65 WARNING:** Engine exhaust from this product contains chemicals known to the State of California to cause cancer, birth defects, or other reproductive harm.

**Safety Labels**

The following **WARNING LABELS** are found on your cleaning unit. These labels point out important **Warnings** and **Cautions** which should be followed at **all** times. Failure to follow warnings and cautions could result in fatality, personal injury to yourself and/or others, or property damage. Follow these instructions carefully! **DO NOT** remove these labels.

**NOTE:** *If at any time the labels become illegible, promptly replace them.*

Lower Front Panel Decal with warning labels  
86316190

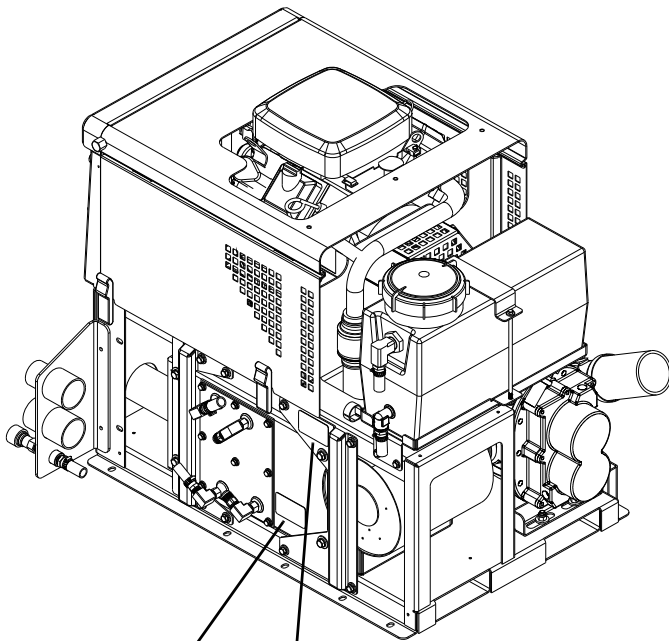
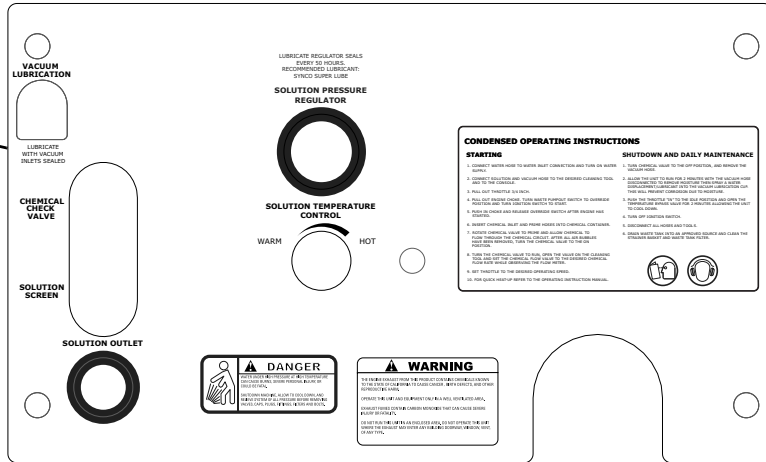

**WARNING**  
Rotating machinery can cause serious injury. Do not operate with guards off.

Warning Label  
86186520  
PRV # 500769

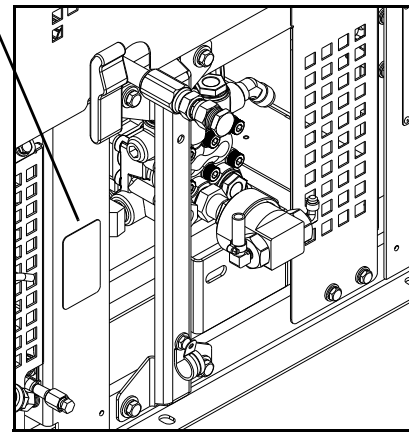

**CAUTION**  
Hot surface. Do not touch.

Caution Label  
86186530  
PRV # 500770

## Technical Specifications

ITEM	DIMENSION/CAPACITY
Engine speed	3200 rpm 1400 rpm (idle speed)
Water pump rpm	1655 rpm
Vacuum pump rpm	3200 rpm
Water flow rate	3.5 GPM (maximum)
Water pump pressure	1200 PSI (maximum)
Vacuum relief valve	13" Hg
Waste tank capacity	60 gallons
Console weight	500 lbs. (590 lbs. If mounted on water tank)
Console weight (with waste tank & accessories)	710 lbs (If waste tank is empty) (1225 lbs. If waste tank is full) (1740 lbs. If auxiliary water tank and waste tank are full)
<b>TORQUE VALUES</b>	
Engine rear / vac pump pulley	21 foot lbs
Engine front / water pump pulley	8 foot lbs

### JET SIZING:

Manufacturer recommends floor tool tip sizing not exceed a total of ".030". Using larger jet sizes on your cleaning unit may reduce cleaning temperatures.

Example: Tri-jet wand uses three 95010 jets (95° spray angle w/ 010 orifice).

$$01 \times 3 = 030$$

Upholstery tool jet size: 80015

Stair tool jet size: 9502

### Installation Requirements

Prior to starting the installation, first read the **ENTIRE** "Installation" section of this manual. Since the cleaning unit (with empty waste tank and accessories) weighs approximately 710 lbs.(800 lbs. if mounted on water tank), consider the following recommendations before installing this unit.

1. The unit should **NOT** be mounted in any motor vehicle of less than **1/2 ton capacity**, or **3/4 ton** if equipped with one or more auxiliary fresh water tanks.

#### **⚠ CAUTION:**

**DO NOT exceed the vehicle's axle weight limit. Include the console, full tanks, accessories, and operators in calculations.**

2. If mounting in a trailer, make certain that the trailer is rated for the total weight of the **UNIT AND TRAILER**. Electric or hydraulic brakes should be provided, and a strict compliance with any State and Federal vehicle laws must be maintained.
3. The vehicle tires should have a load rating above the combined vehicle and unit weight.
4. We do not recommend using flooring materials that absorb water. This could result in rust and corrosion of the vehicle floor.
5. Padding under rubber floor mats should be removed before installing this unit.
6. We highly recommend using a galvanized drip tray under the console (Part # 86050370, or Part # 86050380, for units mounted on a water tank.)
7. If using a trailer, the console should be positioned so that it balances properly with respect to the axle. Ten percent (10%) of the total trailer weight, not exceeding 800 lbs, should be on the tongue. Load the unit and accessories appropriately.

### Fuel Requirements

**Use unleaded gasoline ONLY. DO NOT** use any gasoline additives. We recommend the use of clean, fresh, unleaded gasoline intended for automotive use. High octane gasoline should **NOT** be used with the engine on this unit. These engines are NOT designed to use E-85 or Flex Fuels.

### Engine Oil Requirements

Use high quality detergent 10W-30 oil of at least API (American Petroleum Institute) service class SG, SH, SJ or higher.

**NOTE:** *Using a lower service class oil or extending oil change intervals longer than recommended can cause engine damage.*

**NOTE:** *Synthetic oils meeting the listed classifications may be used with oil changes performed at recommended intervals. However to allow piston rings to properly seat, a new or rebuilt engine should be operated for at least 50 hours using standard petroleum based oil before switching to synthetic oil.*

### Altitude Requirements

Engines perform differently with increases/decreases in altitude. Be sure to check engine speeds during initial installation. See engine speeds in Technical Specifications section.

**NOTE:** *To ensure correct engine operation at altitudes above 1525 meters (5000 ft), it may be necessary to have an authorized Briggs dealer install a special high altitude jet kit in the carburetor. If a high altitude kit has been installed, the engine must be reconverted to the original jet size, before it is operated at lower altitudes, or overheating and engine damage can result.*

### Chemical Requirements

The unit, due to its chemical injection pump design, can be used with a variety of water-diluted chemical compounds (either acidic or alkaline), depending on the job to be done. However, to obtain optimum results with this unit, we recommend using the Prochem line of chemicals. For information on using the cleaning compounds, refer to the chemical manual.

### Water Requirements

Hard water deposits will adversely affect the plumbing and heat exchange systems on this unit. The map below will give you an idea of where areas of high water hardness may occur. However, any water supply obtained from a well is almost always hard water and a water softener will be needed to protect your equipment.

**NOTE:** *Equipment malfunction or component failure caused by hard water scaling is NOT covered under the warranty.*

If you are operating this unit in an area where the unit will be using water in which the hardness exceeds 3-1/2 grains, we highly recommend a suitable water softener be installed. If using a water softener, it must have a five (5) GPM (or greater) flow capacity without any hose constrictions.

Using a water softener will reduce maintenance and decrease down time caused by hard water scaling. It will also allow cleaning chemicals to be more effective in lower concentrations.

If you require a water softener, your dealer has a model to meet your needs. Please contact your nearest distributor for information, price, and availability.

**Hard Water Map**

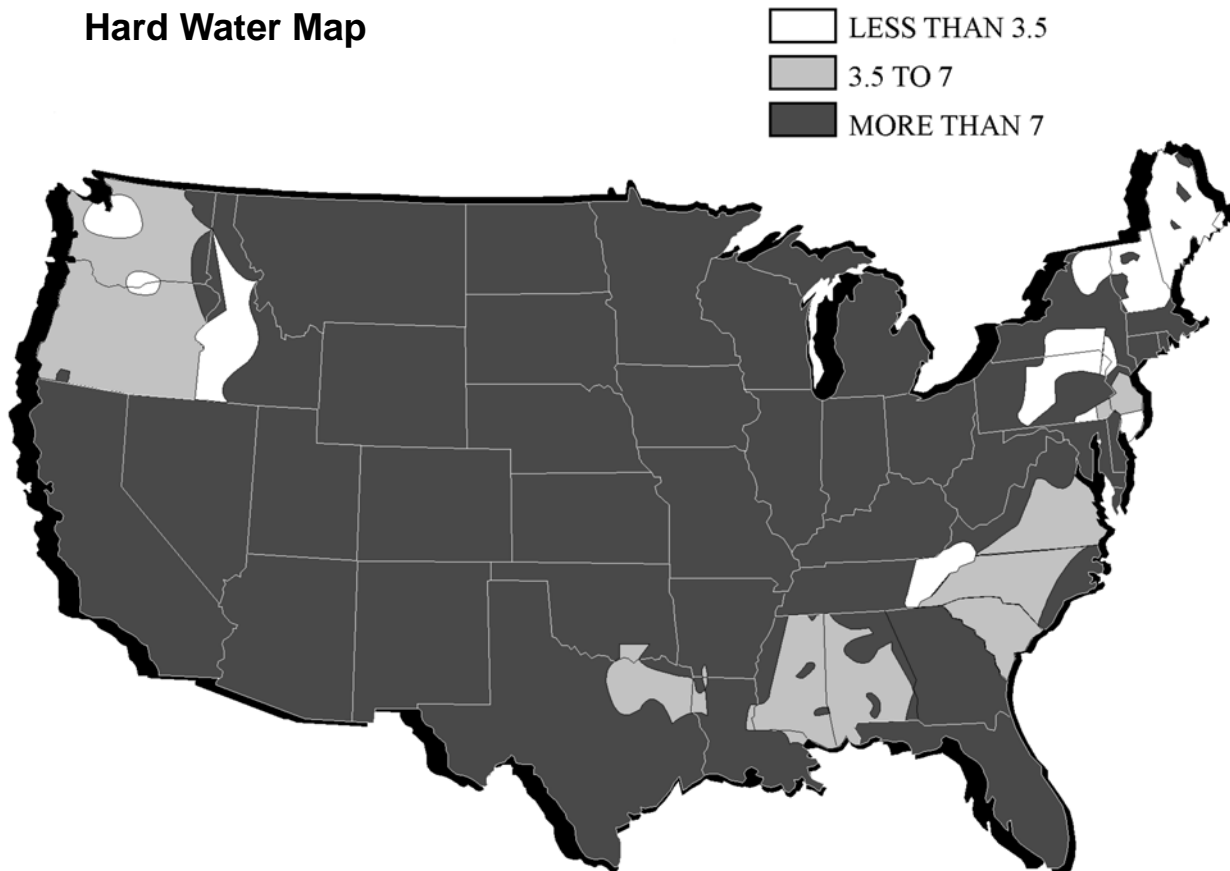

Components

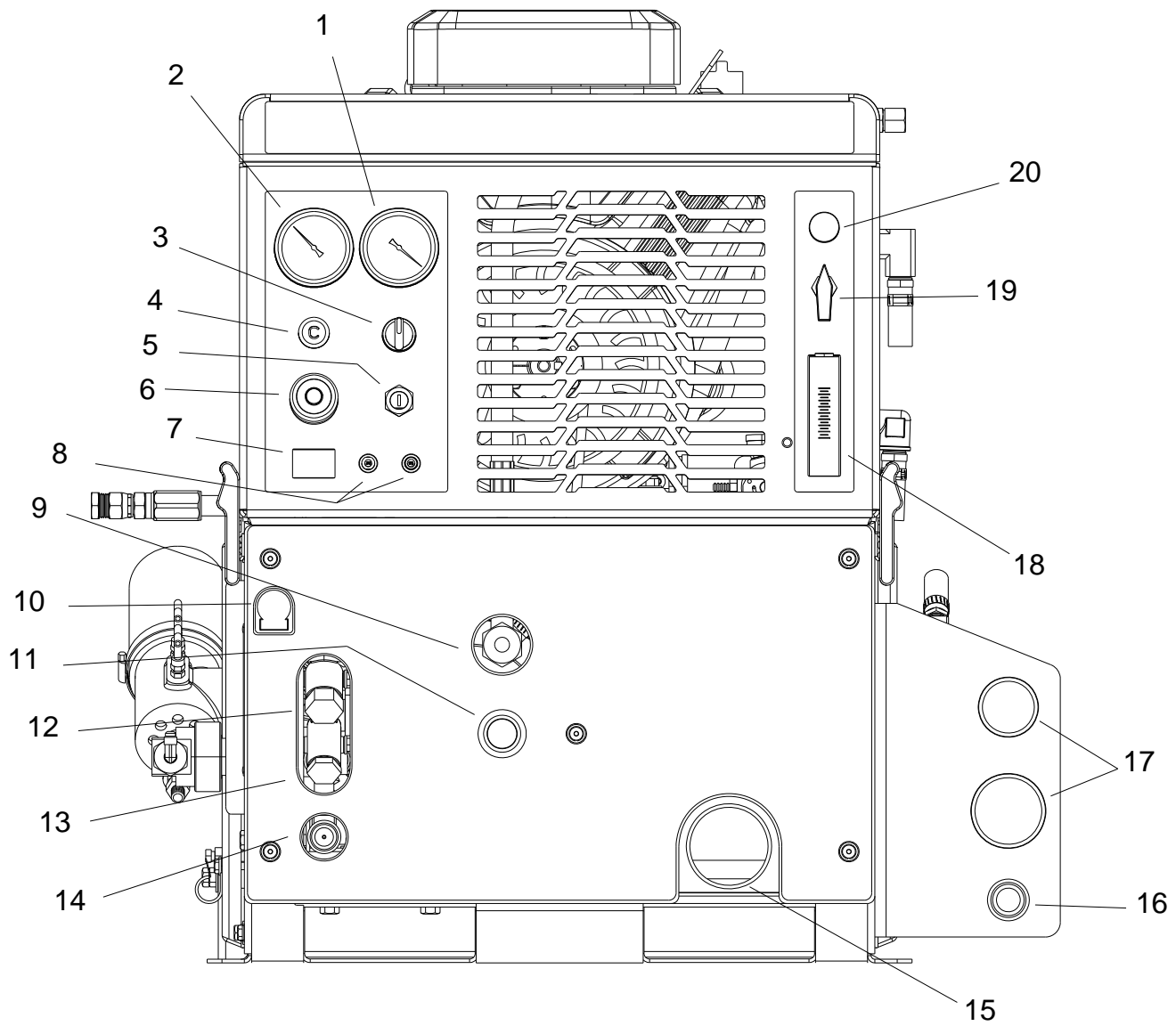

**1. VACUUM GAUGE**

This gauge indicates in inches of mercury how much vacuum the system is producing at any given time.

**2. SOLUTION PRESSURE GAUGE**

This gauge registers the amount of pressure in the system.

**3. WASTE PUMPOUT / OVERRIDE SWITCH**

This switch actuates the optional waste pumpout.

**4. CHOKE**

The choke is for restricting air to the carburetor, this enriches the fuel mixture. The primary purpose is for starting in cold temperatures. When the cable is pulled out air is restricted, when pushed in the engine is in run position.

**NOTE:** Do NOT run engine with choke pulled out.

**5. IGNITION SWITCH**

The key switch controls the power for the machine. To turn the machine on, rotate the key clockwise while holding waste pump out switch to the override position until the engine starts. When machine is running let off the override switch and the engine will continue to run. To turn power off, rotate key counter clockwise to stop position, engine will then stop.

**6. THROTTLE**

The throttle cable is used to set the speed of the engine (rpm). The engine speed (rpm) may be increased by releasing the collar lock, pushing in the red button on the end of the handle, and pulling the handle straight out. Engine speed may be changed in smaller increments by rotating the throttle handle clockwise or counter-clockwise. The collar lock can be tightened to prevent the throttle from slipping and changing the engine speed.

**7. HOUR METER**

The hour meter records the number of hours the unit has run. This serves as a time recorder for servicing the machine.

**8. CIRCUIT BREAKERS**

These serve to protect the circuits from electrical spikes and over loads and protects wires from damage.

**9. SOLUTION PRESSURE REGULATOR**

The pressure regulator sets the pressure of the solution system. This spring loaded valve can be adjusted up or down setting the pressure of the unit. The pressure is increased by turning the valve clockwise, or reduced by turning the valve counter clockwise. (This valve must be maintained in accordance with this manual's maintenance table.)

**10. LUBRICATION CUP**

The lubrication cup allows lubricant spray to reach the vacuum blower.

### 11. TEMPERATURE CONTROL VALVE

This valve allows the operator to control the solution temperature by bypassing hot water to the waste tank, for low temperature cleaning such as upholstery. Turning the valve counter clockwise opens the valve. Turning clockwise closes the valve and has the effect of stopping water from bypassing.

### 12. CHEMICAL CHECK VALVE

The chemical check valve allows chemicals to enter the system and travel in a singular direction to the wand. The chemical check valve prevents chemicals from traveling upstream into the solution system of the unit.

### 13. SOLUTION SCREEN

The solution screen is located on the front of the machine. The function of this screen is to trap foreign particles from exiting the machine and plugging the orifices of the cleaning tool.

### 14. SOLUTION OUTLET

The solution outlet is the connecting point for the high pressure cleaning hoses. This outlet has a quick disconnect that allows hoses to be plugged into the unit.

### 15. EXHAUST

Exhaust fumes contain carbon monoxide which is an odorless and deadly poison that can cause severe injury or fatality. **DO NOT** run this unit in an enclosed area. **DO NOT** operate this unit where the exhaust may enter any building doorway, window, vent, or opening of any type

### 16. WATER INLET

This quick connect allows the water supply hose to be connected to the unit.

### 17. VACUUM INLET

The vacuum inlet serves as the connecting point for vacuum hoses.

### 18. FLOW METER

The flow meter is a gauge to indicate how much liquid chemical is being introduced in the water system. The quantity can be increased by turning the chemical flow knob counter clockwise.

### 19. CHEMICAL CONTROL VALVE (PRIME POSITION)

This valve allows the chemical to circulate through the chemical system with little or no restriction. It also purges out air that may be trapped in the lines and cavities of the chemical pump. By turning the valve clockwise the injection system is enabled.

### 20. CHEMICAL METERING VALVE (CHEMICAL CONTROL VALVE IN RUN)

The chemical metering valve regulates the amount of chemical that is injected into the system. Clockwise rotation of the knob closes the valve. Counter clockwise rotation opens the valve, allowing more chemical to enter the system.



## Vacuum System

The engine turning an air pump (vacuum pump) generates vacuum. The air is channeled in one side of the vacuum pump, compressed and discharged on the opposite side, creating airflow. This airflow is used to do the work necessary for the extraction process. A vacuum nozzle applied to the carpet surface removes moisture, dirt and spent chemicals. These elements are conveyed back to a separating tank utilizing hoses and the force of air. Particles of moisture and dirt are separated in the vacuum tank using a series of changes in direction and velocity. The air is then filtered and rushes into the vacuum pump.

The vacuum pump also heats incoming air as it is compressed. The hot discharged air is forced down stream into a silencer for noise abatement. Exiting the silencer, this hot air is forced through the heat exchanger

The vacuum pump speed is factory set to maximize vacuum pressure and provide sustained system life. Do not alter the vacuum speed outside the recommended range shown in the Technical Specifications section.

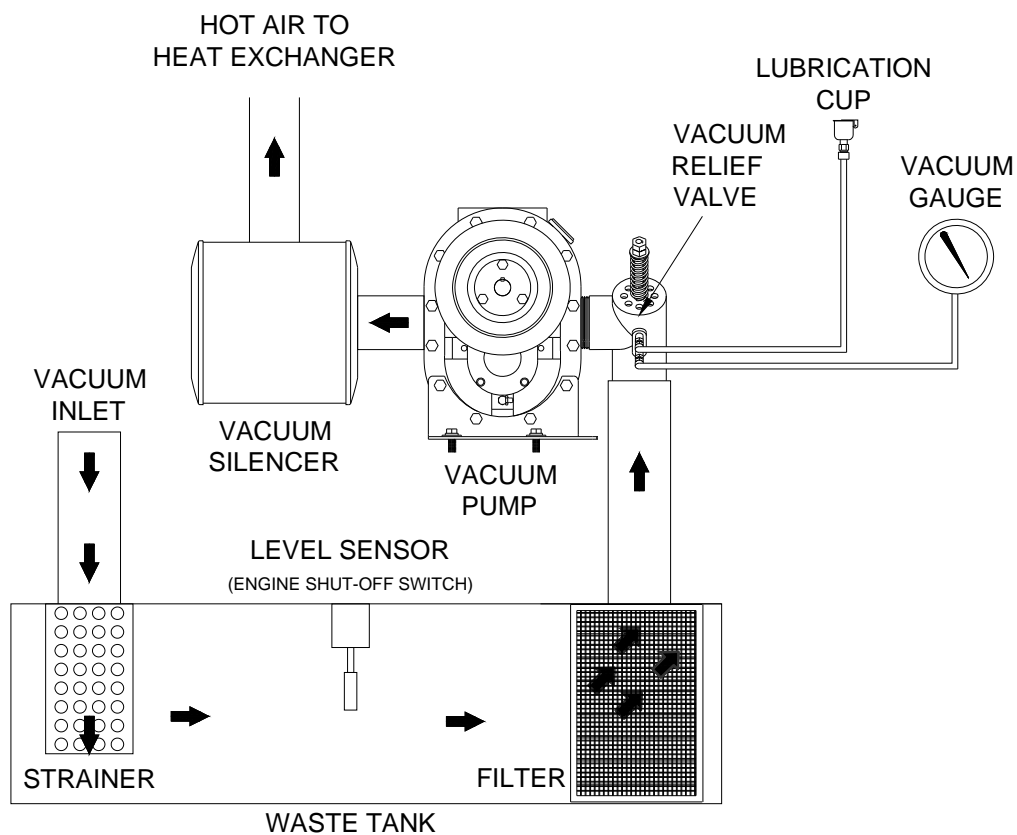

**⚠ WARNING:**

**Always wear hearing protection and proper personal protection equipment when operating unit.**

### **Water Pumping and Heat Transfer System**

Cold water enters the console through the water inlet. When the water box is full the valve will automatically shut off.

Water flows from the water box, into the solution pump where it is pumped to the pressure regulator manifold which provides and maintains the desired pressure setting.

The pressure regulator manifold includes a pulse hose, which helps reduce pressure spikes from the pump.

A certain amount of water is by-passed from the pressure regulator due to an over pumping capacity of the solution pump. Water that is not called for in the cleaning process is channeled through the copper bypass heat exchanger core in the front of the heat exchanger. This bypass water may circulate several times through the bypass heat exchanger core allowing the water to be pre-warmed.

The gases coming from the vacuum pump and the engine are forced through the second heater core creating the hottest area of the heater box, and increasing the heat transfer to the circulating water.

The hot water passes to the solution outlet manifold where cleaning chemicals are injected from the chemical pulse pump. This manifold serves as a connecting point for the high-pressure hoses. Also a check valve is located in this outlet manifold prohibiting chemicals from backing up into the system.

The cleaning solution then passes through high-pressure hoses and is distributed by the cleaning tool to a surface that is being cleaned, completing the water pumping and heating cycle of the cleaning unit

### **Heat Exchanger**

The water temperature in the plumbing system is raised for better cleaning. This happens in the heat exchanger. The heat exchanger is made up of two stages. These two stages are the high stage, and the pre-warming stage.

The vacuum pump heats incoming air as it is compressed. The rear core receives its heat from the mixing of the engine exhaust and the vacuum pump exhaust. This mixture of hot air and gases is then forced through the rear core and on through the front heat exchanger core.

This core becomes extremely hot and should not be touched while the machine is in operation. Allow the machine to cool down completely before attempting to service this area.

The front core continues to extract heat from the mixed gases; but, this heat is used to pre-heat the water box as a preliminary hot water reservoir.

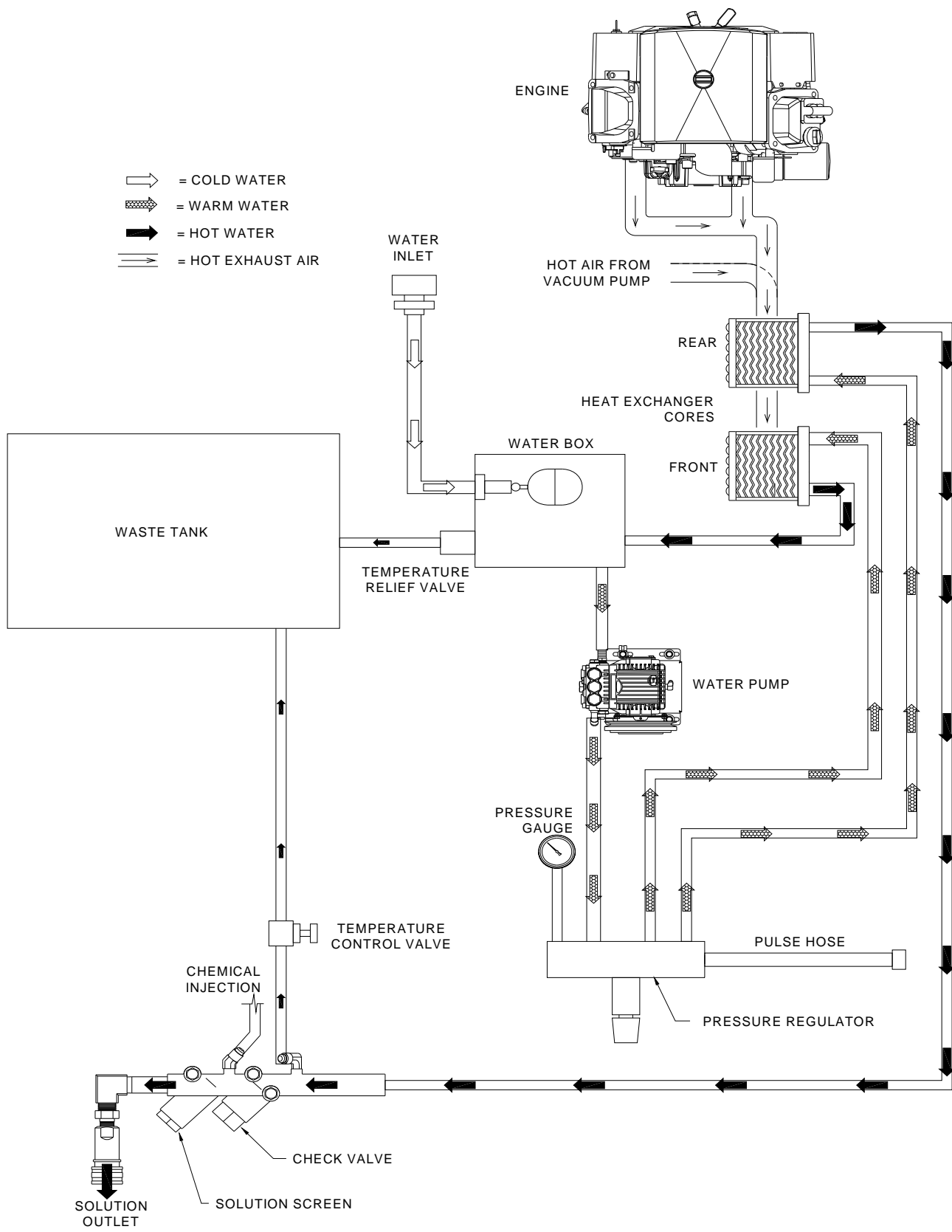

## Chemical Injection System

The chemical injection system is unique in that it utilizes the pressure spikes generated by the high-pressure water pump to move chemical into the main pressure stream. The high pressure spikes move the diaphragm in the chemical pulse pump forcing small amounts of liquid chemical to be moved in a single direction of flow with the aid of two check valves.

The chemical is sucked up from the container and fed through the flow meter to the chemical pulse pump where it is pressurized.

After being pressurized by the chemical pulse pump the chemicals are fed to the control valve which directs the chemical either into a bypass loop to purge air from the system or in to the solution metering valve.

The metering valve creates an orifice allowing the correct amount of chemical to enter the outlet manifold. The outlet manifold assembly is complete with a check valve that will not allow the chemicals to travel upstream into the plumbing system of the unit.

The chemicals are then mixed with hot pressurized water to make a solution for the chosen cleaning application.

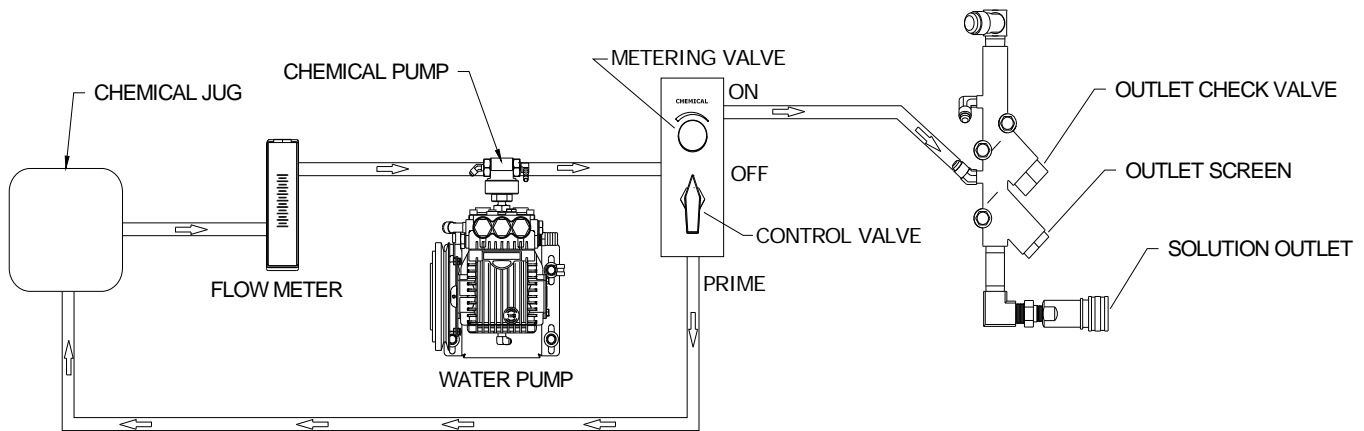

## Pre-Run Inspection

Operate this unit and equipment only in a well-ventilated area. Exhaust fumes contain carbon monoxide, which is an odorless and deadly poison that can cause severe injury or fatality. **DO NOT** operate this unit where the exhaust may enter any building doorway, window, vent, or opening of any type.

## Check For Adequate Fuel

Check the fuel tank to be certain there is adequate fuel to complete the job. This unit uses approximately .75 – 1.00 gallons of fuel per hour, depending on the speed setting.

## Remove Tools From Vehicle

Remove any **tools** or **hoses** from the van, which you will require.

## Water Supply Connection

**NOTE:** Before connecting your water hose to the supply faucet, flush out the faucet until the water is free of any debris. Flush out any debris which may be in your water inlet hose.

1. Connect the **water supply hose** to the side panel **water inlet** quick-connect on the right front of the console. Connect the hose to the water supply faucet.

**NOTE:** Never use your waste pump outlet hose as a water inlet hose. Use only clean hoses for water inlet.

2. Turn the **water supply faucet** on. The water will fill the **water box**.

## High Pressure Hose

Before starting the unit, connect the **pressure hose** to the **outlet connection** at the front of the unit. Connect the **cleaning tool** to the **pressure hose**.

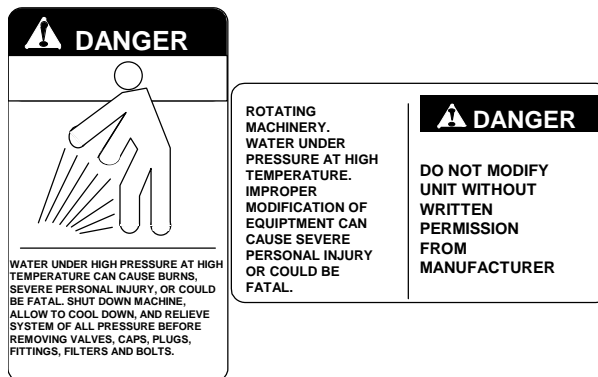

## Vacuum Hose

Connect the **vacuum hose** to the **vacuum inlet** connection at the front of the unit. Connect the other end of the **vacuum hose** to the **cleaning tool**.

## Filters

Ensure all filters on machine and in waste tank are free of debris.

### Priming the Chemical Pump

1. Connect water hose to water inlet connection and turn on water supply.
2. Connect cleaning and vacuum hoses to the desired cleaning tool and console.
3. Insert chemical inlet and prime tubing into chemical container.
4. Pull out engine choke, turn waste pumpout switch to override and turn ignition key to start.
5. Push in engine choke after engine has started.
6. Set throttle to idle speed.
7. Fill chemical container and inspect chemical filter.
8. Turn chemical control valve to prime and allow chemical to circulate.
9. After all air bubbles have been removed from chemical tubing, turn the valve to the horizontal (off) position.
10. Open the chemical metering valve, and turn the chemical control valve to run, trigger the solution flow valve on the cleaning tool.
11. Set the desired chemical flow rate while observing the flow meter indicator.
12. Set throttle to maximum position with vacuum port blocked off for quick unit heat up.

**NOTE:** Do not run the machine with the port blocked for more than 2 minutes to avoid overheating.

### Waste Pump (Optional)

1. If your unit is equipped with an automatic waste pump, connect one end of a garden hose to the pump-out connection and the other end to an appropriate waste disposal.
2. Turn the pump-out switch on the control panel to the ON position. The waste pump will operate automatically throughout the cleaning operation.

We recommend that you use a 3/4" I.D. water hose as a waste pump outlet hose. DO NOT use a hose smaller than 5/8" I.D.

NEVER use your automatic waste pump outlet hose as a water inlet hose.

### **WARNING:**

**Always dispose of waste in accordance with Local, State, and Federal laws.**

Once you have completed steps 1 through 8, proceed with the cleaning operation. Your unit should be in the correct throttle position for your cleaning operation or extracting. A float switch located inside the waste tank will automatically shut down the unit when it reaches its full capacity. When this occurs, empty the waste tank before continuing.

### Cleaning

Observe the following guidelines, while cleaning:

1. Before proceeding make sure the nozzles are functioning properly.
  - a. To check, hold the wand about one foot above the surface to be cleaned and open the wand valve. A full spray should be observed from the cleaning nozzles.
  - b. If the nozzles are not showing a full spray pattern, adjust nozzles for proper pattern, clean, or replace nozzles, if required.
2. Normally chemical is applied on the push stroke of the wand when cleaning and vacuuming is done on the pull stroke. For heavily soiled carpets the wand may be used in a scrubbing manner, apply chemical in both push and pull strokes. Always finish up an area with a vacuum stroke.
3. When cleaning, keep the working opening (mouth) flat on the surface being cleaned. Keep the wand moving when the valve is open.
4. The unit will automatically shut-down when the waste tank is full. This will prevent water being drawn into the vacuum pump. If shut-down occurs, empty the waste tank before proceeding.

## Upholstery Cleaning

Upholstery tool, part #86285260, PRV NO. 78513

1. Set temperature as desired and slow down the engine speed slightly to minimize excess solution heat.
2. Use one (1) "86229980, PRV NO. 80015" spray tip in tool.

## Shutdown and Daily Maintenance

1. Close chemical metering valve.
2. Allow the unit to run for 2 minutes with the vacuum hose disconnected to remove moisture. Spray WD40 (or equivalent) into the vacuum lubrication cup. This will prevent corrosion due to moisture.
3. Set engine throttle at idle position and allow the water temperature to cool down, utilizing the temperature control valve in the open position to bleed off residual hot water left in the system.
4. Close temperature control valve and turn off ignition switch.
5. Disconnect all hoses and tools.
6. Drain waste tank and rinse with clean water.

## Freezing Protection

**If the unit is exposed to freezing weather the water in the unit may freeze, causing SERIOUS DAMAGE to the unit. To avoid this, the following is recommended during the cold weather season.**

When the unit is not in use, always park it in a heated building.

While in operation, avoid long shutdowns as the unit provides heat while running. Shut it down just prior to leaving for the next job.

If a heated building is not available, we recommend that you winterize the unit with anti-freeze. At present, it is only possible to winterize units, which do not have an auxiliary water tank. Units with auxiliary water tanks must be stored in a heated building when not in use.

## Overheating Protection

Air cooled engines rely on the flow of air over the engine for cooling operations. Ensure that there is sufficient air flow in the van. **Never** operate the unit with all the vehicle doors closed and no alternative ventilation system.

**This unit must be operated with the vehicle or trailer doors open in order to ensure adequate engine ventilation.**

### Winterizing the Unit

1. Shut off the water supply. Disconnect the **water inlet hose** from the front of your console.
2. Connect all **high pressure hoses and tools** that may have water in them.
3. Start the unit. Open the tool valve until water pressure drops and water stops flowing.
4. Turn off the engine.
5. Fill the water box with approximately two gallons of 100% glycol base anti-freeze.
6. Start the unit.
7. Open the tool valve until anti-freeze begins to come out of the tool. Recover **ALL** anti-freeze that comes out of the tools into an approved container. We strongly recommend that you re-cycle and re-use the anti-freeze.
8. Turn off the unit. Attach the winterizing loop hose with attachment, Part #86260700, to the solution outlet connection and the water inlet connection.
9. Start the unit and allow it to run for approximately 3 minutes with the winterizing loop hose attached.
10. Open temperature control valve and allow anti-freeze to flow to waste tank.
11. Prime the chemical system with 50/50 anti-freeze/water mix. Insert the chemical inlet and prime discharge tubes into the anti-freeze container. Turn the chemical valve to PRIME until anti-freeze begins to flow out of the prime hose.
12. Now turn the chemical valve to the open position, making certain that the flow meter indicates flow and that all anti-freeze drains out of the chemical hose into an approved container, after 30 seconds, turn off both valves.

Repeat this procedure with all the remaining tools. After all tools and pressure hoses have been filled with anti-freeze, disconnect and store them.

### **WARNING:**

**When disposing of used anti-freeze, observe local laws and regulations. Do not drain onto the ground or into storm drainage systems.**



## Removing Anti-Freeze From the Unit

1. Connect one end of the **winterizing loop hose** to the solution outlet connection. Place the other end of the loop hose, without the attachment, into an approved container.
2. Start the unit. Allow the anti-freeze to flow into the container until flow stops.
3. Fill the water box with fresh water and repeat step #2.
4. Connect the **water inlet hose** to the water inlet connection on the console. Turn the water supply on.
5. Connect all **solution hoses and any tools** which require purging of anti-freeze to the solution outlet connection(s).
6. Open the tool valves and drain the anti-freeze into an approved container until the flow is clear and all anti-freeze is purged from the tools and hoses.

7. Place the chemical prime hose into the approved container. Submerge the chemical inlet hose in water. Turn the **chemical valve** to the PRIME position until clear water comes through the prime hose, and then remove the prime hose from the container.
8. Turn the **chemical valve** to the ON (CHEMICAL) position. This will allow water to flow into the other side of the system.

Once all of the anti-freeze is removed, the unit is ready to use.

Eventually, the anti-freeze in your storage container will become diluted with water. If the anti-freeze level drops below 50% of the total, dispose of it and start with fresh 100% anti-freeze.

### **WARNING:**

**When disposing of used anti-freeze, observe local laws and regulations. Do not drain onto the ground or into storm drainage systems.**

**Service Schedule**

Engine	Daily	Check engine oil level. *** Fill to proper level (Do not overfill)
Vacuum Pump	Daily	Spray WD-40 in lubrication cup at front of console for 5 sec.
Water Pump	Daily	Check oil level.** Fill to proper level (Do not overfill)
Solution Outlet Strainer	Daily	Check strainer for blockage, remove any debris
Vacuum Inlet Filter (In Waste Tank)	Daily	Clean filter, inspect, replace if damaged
Vacuum Hoses	Daily	Wash out with clean water
Automatic Waste Pump	Daily	Inspect and remove any debris or sediment
Chemical Filter	Daily	Inspect daily
Vacuum Pump	Weekly*	Check oil level. Fill to proper level
Water Box Float Valve	Weekly	Check for proper seating and shut-off
Water Pump Inlet Filter	Weekly*	Check for debris and clean
Battery	Weekly*	Check for proper fluid level. Fill with distilled water only
Solution Outlet Screen	Weekly*	Inspect and remove any debris or blockage
High Pressure Hoses	25 hrs	Inspect for damage or impending damage
Pressure Regulator	50 hrs	Lubricate o-rings
Pressure Regulator	50 hrs	Lubricate plug behind spring
Engine	50 hrs	Change engine oil***
Engine	50 hrs	Change oil filter***
Battery	100 hrs*	Clean battery terminals
Automatic Waste Pumpout	100 hrs	Clean inlet and outlet ports
Belts/pulleys	100 hrs	Check belt wear and tension. Check pulley alignment.
Water Box Float Valve Seal	200 hrs.	Inspect and replace seal as needed
Engine	200 hrs	Service air cleaner elements*
Fuel Pump	200 hrs	Check hose connections
Fuel Hose, Fuel Fittings	200 hrs	Check connections and hose wear
Engine	200 hrs	Check spark plugs for carbon deposits and proper gap
Chemical Valves	200 hrs	Inspect and/or adjust packing nuts
Heat Bypass Valve	200 hrs	Inspect and/or adjust packing nuts

Vacuum pump	250 hrs	Lubricate bearing on pulley end with grease
Vacuum Exhaust Heat Exchanger	500 hrs	Inspect cores and remove debris.
Water Pump	500 hrs	Change oil**
Pulley Set Screws & Hub Cap Screws	500 hrs	Check for proper torque value. Re-torque, if required****
Drive Pulley	500 hrs	Inspect, clean and check for pulley groove wear****
Drive Pulley	500 hrs	Check pulley alignment****
Drive Belts	500 hrs	Inspect and clean****
Drive Belts	500 hrs	Check belt tension****
Chemical Pump & Check Valves	500 hrs	Replace diaphragm and check valves.
Vacuum Lubrication Lines	500 hrs	Check for line obstructions. Replace tubing if cracked or damaged
Engine	500 hrs	Replace in-line fuel filter on engine.
Heater Core	500 hrs	Clean and inspect.
Engine	1000 hrs	Replace spark plugs.
Check Valve (Solution Outlet)	1000 hrs	Inspect, clean, and repair, if needed.
Waste Tank Shut-off Float Switch	Monthly	Check for debris hindering movement
Vacuum pump	Yearly	Drain and replace oil*****
Waste Tank Filters/Strainers	Yearly	Check for damage and blockage. Replace if needed.
Engine	Yearly	Replace air cleaner element
Engine	3 years	Replace ignition wires.

\* Or as often as required

\*\* Change water pump crankcase oil after the first 50 hours

\*\*\*Change engine crankcase oil and filter after the first 5 hours

\*\*\*\*Perform drive belt, pulley and hub maintenance after the first 25 hours of operation, and then again at 100 hours

\*\*\*\*\*If using Tuthill Pneulube synthetic lubricant, 4500 hours or every 2 years, whichever comes first

### Key Checkpoints

**NOTE:** *Initiation of a planned preventative maintenance program will assure that your unit has optimum performance, a long operating life, and a minimal amount of "down" time.*

### External Fuel Pump Maintenance

The power plant for the unit receives fuel from the main gas tank of your van/truck. An external fuel pump that provides this fuel is located on the underside of the van/truck. Loose fittings and hose connections will cause your unit to perform poorly. Follow the recommended fuel pump maintenance in the Maintenance Schedule in this manual. Refer any additional questions to your dealer.

### Chemical Supply System Maintenance

The chemical supply system pulls chemicals from your chemical bottle utilizing a pump that works off the water pump pulsing. Any clogged filters or loose connections will result in a chemical supply system malfunction or a malfunction at the cleaning tool. Maintenance of the solution outlet check valve and strainer are vital to effective cleaning operation and minimal unit downtime. Additionally, the hoses related to supplying water and chemical to the outlet manifold are under high pressures and experience thermal expansion and contraction. Periodic inspections of these hoses for tears, cracks, and failing connectors are necessary to avoid unwanted leaks. To keep your chemical system functioning properly, follow the chemical pump and solution outlet maintenance in the Maintenance Schedule in this manual. Refer any additional questions to your dealer.

### Heat Exchanger System Maintenance

The heat exchange system in your unit transfers energy from the exhaust of the power plant and blower discharge air and to the solution supply system. The heat transfer of this system is highly dependent on the surface area contact in the heat exchanger cores located in the heat exchanger box. This surface area amount is adversely minimized when the supplied water is not softened to recommended levels. Hard water will result in scaling on the inside walls of the heat exchanger tubes. It is recommended that you use a manufacturer approved water softener to avoid premature heat exchanger core failure. Contact your local dealer for advice on the water hardness levels in your area.

Additionally, the heat exchanger tubes are very sensitive to freezing conditions. As the water freezes during cold conditions, it expands in the heat exchanger tubes and causes damage. Often the tubes are cracked and require the replacement of the heat exchanger core. Refer to the Freeze Protection instructions section in this manual. Refer any additional questions to your dealer.

## Engine

(Refer to **Briggs & Stratton Vanguard Service And Repair Instructions Manual** for specific instructions)

1. Check the engine oil level **daily**, when in use. Make certain that proper oil level is maintained. **NEVER** overfill.
2. Change the break-in oil after the first **50 hours** of operation. Thereafter, change oil every **50 hours** of operation. **USE ONLY BRIGGS & STRATTON BRAND OIL FILTERS (PN 86174450, PRV NO. 42-902158) ANY OTHER TYPE OIL FILTER WILL VOID YOUR ENGINE WARRANTY.** Torque drain plug to 10 ft lbs.

**Oil Recommendation.** See "ENGINE OIL REQUIREMENTS" in Operations section.

**NOTE: Using other than service class SG, SH, SJ or higher oil or extending oil change intervals longer than recommended can cause engine damage.**

3. Check the spark plugs every **200 hours**. Clean if necessary. Replace the spark plugs every **1000 hours**. **NOTE:** Never sandblast spark plugs. Spark plugs should be cleaned by scraping or wire brushing.
4. Replace the air cleaner element every **year**.
5. Replace the in-line gas filter every **500 hrs**.

**NOTE: If service or repair is required, contact an authorized Briggs & Stratton Service Center. You will need to provide the serial number of the engine.**

## Vacuum Pump Maintenance

(Refer to manufacturer's manual for specific maintenance instructions)

The total function of the unit is based around the performance of the vacuum pump. Heat transfer used to raise the temperature of the solution is gained from the air drawn by the vacuum pump and solution is removed from the carpet with the vacuum suction of the vacuum pump. General maintenance actions for the vacuum pump as listed in this manual are vital to prolonged vacuum pump operations. Daily lubrication of the pump is required to avoid seizure of the system. Also, waste tank filters and strainers must be maintained to prevent unwanted debris from entering the vacuum pump.

### **WARNING:**

**DO NOT service this unit while it is running. The high-speed mechanical parts as well as high temperature components may result in severe injury, severed limbs, or fatality.**

**NOTE: Use the hour meter as a guide for coordinating the maintenance schedule.**

## Vacuum Pump

Refer to the Vacuum Pump Operation and Service Manual for specific instructions.

**Lubrication:** We recommend that you use Tuthill Pneulube Blower Lubricant in the gear end of the vacuum pump for all operating temperatures. Tuthill Pneulube is formulated especially for positive displacement blower service to provide maximum blower protection at any temperature. One filling of Tuthill Pneulube will last a many times longer than a premium mineral oil.

**NOTE:** Tuthill Pneulube (Part# 86318420) is the oil in the vacuum pump. Topping off or adding petroleum oil to synthetic oil is NOT recommended.

1. Check the oil level **daily** to assure the proper level. **PROPER LEVEL** cannot be overemphasized. Too little oil will ruin bearings and gears. Too much oil will cause overheating. Use the illustration as a guide when adding oil.
2. To prevent rust from building up inside the vacuum pump (if moisture exists) we have provided a lubrication cup on the front of the unit.

First run the unit at least **1 minute** to remove any moisture from the vacuum pump. Next, fill the lubrication cup with WD-40, or a similar lubricant, for **5 seconds** while the unit is running and the vacuum inlets are sealed. Do this at the end of **each working day**.

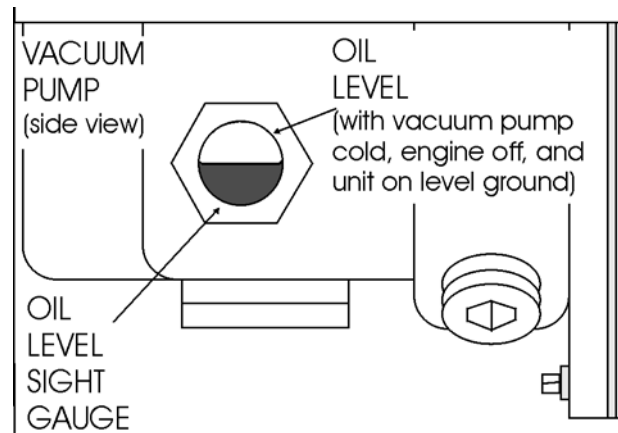

3. Drain, flush and replace oil **every 1500 hours or yearly, whichever comes first**. Change oil more frequently if inspection so indicates. With Tuthill Pneulube, perform the oil change maintenance **every 4500 hours or every 2 years, whichever comes first**.
4. Vacuum pump lubrication is vital to performance of our pump. Failure to follow the maintenance schedule in the "Maintenance Schedule" can lead to permanent damage to your blower.  
Refer to the Vacuum Pump Operation and Service Manual for specific instructions.
5. Bearings on the drive end of the blower require grease lubrication every 250 hours of operation.

## Water Pump

Refer to the Water Pump Operation and Service Manual for specific instructions (P/N 86269900, PRV NO. 67-945621).

1. Check the crankcase oil level **daily** to assure the proper level. Use the illustration as a guide when checking the oil level. If the level has dropped, check for the source of leakage and repair.
2. Use the provided dipstick. Remove red filler cap and insert dipstick. Oil level should be between marks on the dipstick or use a mirror and refer to the illustration.

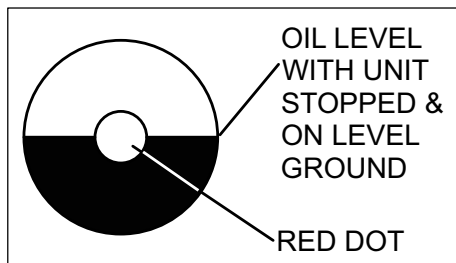

3. Change the crankcase oil with Cat Pump Crankcase Oil, Part #86189080, PRV NO. 05-008016, after the **first 50 hours** of operation. Drain and refill the crankcase oil with Cat Pump Crankcase Oil **every 500** hours thereafter.
4. Other Cat approved oil equivalents are: Mobil DTE 16, Amoco Rykow 68, and Shell Tellus T68.

## Vacuum Inlet Filter (in Waste Tank)

1. The vacuum filter in the waste tank should be removed and cleaned **daily**. If this is done, the filter will last for a long period of time.

## Vacuum Relief Valve

While the unit is running at full RPM, block the air flow at the vacuum inlet connection and read the vacuum gauge. If adjustment is required, shut the unit down and adjust the vacuum relief valve locking nut tension. Start your unit and read the vacuum gauge. Repeat this process until the relief valve opens at 13" Hg.

## Vacuum Pump Drive Belts

To tighten the vacuum pump belts:

1. Loosen the four nuts which hold the vacuum pump mount in place.
2. Turn the adjusting bolts until the proper belt tension is achieved (1/2" deflection in the center of the belt, halfway between the pulleys).

**NOTE:** When adjusting belt tension, make certain that the engine shaft and vacuum pump shaft remain parallel, and the belt tension is equal throughout the belt width.

3. After adjusting, re-tighten the four nuts which hold the vacuum pump mount in position. Check belt alignment with straight-edge.
4. Check for pulley groove wear, clean belts and pulley grooves, check for worn belts, proper belt tension, and pulley alignment after the **first 25 hours** and then again at **100 hours**.

## Water Pump Drive Belts

To tighten the water pump belt:

1. Loosen the bolts which hold the water pump mount to base.
2. Adjust the position of the belt tension adjusting bolt until the proper belt tension is achieved. (1/2" deflection in the center of the belt, halfway between the pulleys).
3. While checking the alignment, tighten the nuts which hold the water pump mount to base.
4. Check belt and pulley every 100 hrs.

## Float Valve (Water Box)

1. Check the float valve weekly for proper operation. If overfilling is a problem, check the plunger for a proper seal. Replace tip on plunger (PN 86192380, PRV NO. 16-808164) if needed.

**NOTE:** *If the float ball has any water inside it must be replaced.*

### **⚠ CAUTION:**

**When replacing float ball, DO NOT over-tighten, as the rod can puncture the ball. Make sure to tighten the nuts on the rod.**

2. Disassemble the valve and check the piston and seat for damage, replace if needed. See the "Illustrated Parts Listing" for a parts break-down.

## Waste Tank Float Valve

The float valve in the waste tank shuts the unit down once the waste tank becomes full. Debris can collect around the hinge of the float valve. Check the float valve for debris at least once a month.

## Waste Tank Strainer Basket

The strainer basket located inside the waste tank should be removed and cleaned whenever it is full of debris. This should be done on at the end of each job.

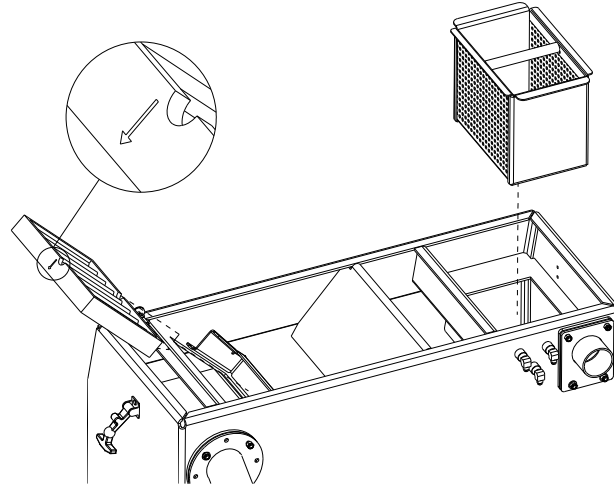

## Waste Tank Vacuum Inlet Filter

The Vacuum Inlet Filter located inside the waste tank should be removed, cleaned and inspected at the beginning of each day. When replacing in tank ensure that flow indicating arrow is pointing down.

## Solution Outlet Screen

Inspect the screen **after the first week** of running the unit by unscrewing the screen and remove any accumulated debris. Inspect the strainer again at **2 and 4 weeks**.

The solution screen should then be inspected **every month**. However, if the Y-strainer has a frequent build-up of debris it should be inspected and cleaned more often.



## Check Valve (Outlet)

Inspect the check valve when rebuilding the chemical pump or as needed. Remove and disassemble the check valve. Check the Teflon seat for debris or abnormal wear. Clean or replace seat if needed.

**NOTE:** *Improper seating of the check valve poppet, damaged spring, or o-rings will cause poor operation of the chemical system.*

For the procedure, see the "General Service Adjustments" section in this manual for details.

## Chemical Pump

Rebuild the chemical pump **every 1000 hours**. This involves changing the diaphragm and check valves.

For the procedure, see the "Chemical Pump" section in this manual for details.

**NOTE:** *Inspect chemical filter daily.*

## Chemical and Heat Bypass Valves

Examine the packing nut on the chemical selector valve, heat bypass valve, and chemical metering valve **every 200 hours**. Keeping these valve packings properly adjusted will eliminate possible leakage from the valve stems and add to overall valve life.

For the procedure, see the "General Service Adjustments" section in this manual for details.

## Pressure Regulator

Lubricate the o-rings and bullet **every 50 hours**. Use o-ring lubricant Part #86265430, PRV NO. 05-008035.

For the procedure, see the "General Service Adjustments" section in this manual for details.

## Vacuum Hoses

To assure maximum hose life, we recommend that the hoses be washed out with clean water at the end of each **working day**.

## High Pressure Hoses

Inspect your high pressure hoses for wear after the **first 100 hours** of use. Inspect **every 25 hours thereafter**. If hoses show any signs of damage or impending rupture, **replace the hose**.

### **WARNING:**

**DO NOT attempt to repair high pressure hoses! Repairing high pressure hoses may result in severe burns and serious injury!**

All high pressure hoses must be rated for 3000 PSI at 250°F. Thermoplastic hoses do not meet these specifications and should not be used. Severe burns and injury may result if the hoses do not meet these requirements.

## Optional Waste Pump-Out

**At the end of each work day**, make certain that you remove any debris or sediment which may be inside the waste pump by pumping fresh water through the pump.

## Service General Adjustments

### **⚠ WARNING:**

USE EXTREME CAUTION while servicing while machine is running. The high-speed mechanical parts as well as high temperature components may result in severe injury, severed limbs, or fatality.

### Engine Speed

This unit uses a factory installed Briggs & Stratton engine governor. The engine speed is adjusted using the throttle control. Pushed in the engine is at idle speed (1400 rpm). With throttle control pulled out, engine operates at maximum rpm (3200).

### Check Valve (Solution Outlet)

Inspect the check valve whenever doing service on the chemical pump or if flow problems occur in the chemical system:

1. Remove the check valve. Be sure the small o-ring for the seat comes out with the check valve.
2. Remove the seat, using a 5/16" Allen wrench.
3. Check the Teflon seat for debris or wear. Clean or replace Teflon seat if needed.
4. Clean the poppet and spring, inspect for wear or damage, and replace as needed.
5. Re-assemble the check valve. Start the seat by hand, tighten using a 5/16" Allen wrench. **DO NOT** over-tighten seat.

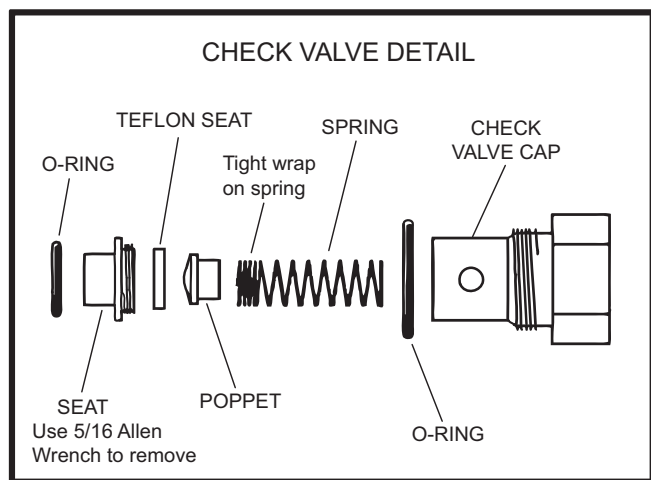

**NOTE:** Improper seating of the check valve poppet, damaged spring or o-rings will cause poor operation of the chemical system.

6. Lubricate the o-rings with o-ring lubricant Part #86255430, PRV NO. 05-008035 and reinstall.

### Water Box

1. Check inlet strainer for debris and blockage. A blocked strainer could damage the water pump if water flow is restricted.
2. Inspect water box float valve for freedom of movement and water leaking past valve.

### Chemical Pump

The only repairs which the chemical pump may require is the replacement of the diaphragm or check valves. To replace the diaphragm, unscrew the cover from the body. When replacing the diaphragm, lubricate the outer edges of the diaphragm with o-ring lubricant Part #86265430, PRV NO. 05-008035 and reassemble. To replace the check valves, unscrew the check valve caps. Replace the check valves and reassemble, using new o-rings.

**DO NOT** attempt to re-use o-rings once the check valves have been removed. See the "Illustrated Parts Listing" for a parts break-down on the chemical pump.

### Water and Vacuum Pump Drive Belts

Use only exact replacement for system drive belts. Use only exact manufacturer and models for replacements.

## Chemical Metering Bypass and Chemical Selector Valves

Examine the packing nut on the metering and selector valves for proper tension every **200 hours**. When turning the knob, there should be a small amount of resistance. If not, slightly tighten the packing nut. **DO NOT** over tighten. Keeping the valve packings properly adjusted will eliminate possible leakage from the valve stem and add to overall valve life.

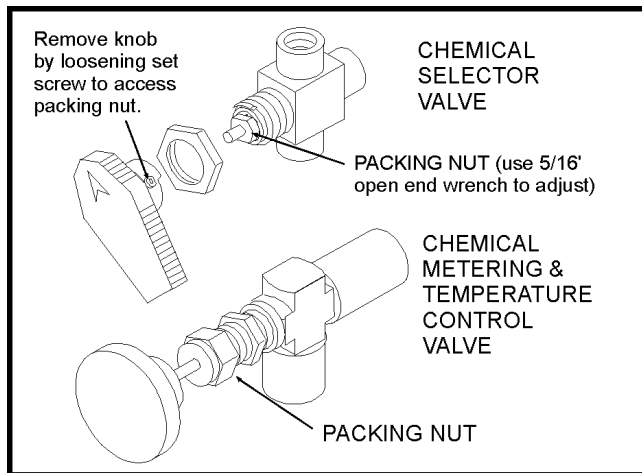

## Pressure Regulator

The pressure regulator serves to maintain water pressure at a preset point and to bypass this water back to the water box.

To adjust:

1. With your unit running, close the cleaning tool. Check the pressure gauge. Open the tool valve. We recommend setting the pressure regulator so that the pressure gauge reads 450 PSI with the tool valve **open**.

When the tool valve is opened, there is an approximate drop of 50 PSI in pressure. **If there is a pressure drop greater than 100 PSI, it may be necessary to lubricate the o-ring in the pressure regulator.**

2. If the pressure regulator requires adjustment, loosen the locking nut, then turn the adjusting body (cap) (while observing the pressure gauge on the control panel) until the desired pressure is obtained. Retighten the locking nut.

## **! WARNING:**

**DO NOT** loosen the adjusting body (cap) all the way (counterclockwise) or remove it while the unit is running.

We recommend that you lubricate the pressure regulator o-ring every **50 hours**, or whenever required. If you do not, the stem may become seized due to inadequate lubrication. If this occurs:

- a. Shutdown the unit.
- b. Relieve all pressure from the water system.
- c. Remove the cap from the pressure regulator and remove the stem with long nose pliers.
- d. Clean and lubricate stem.
- e. Reassemble pressure regulator.

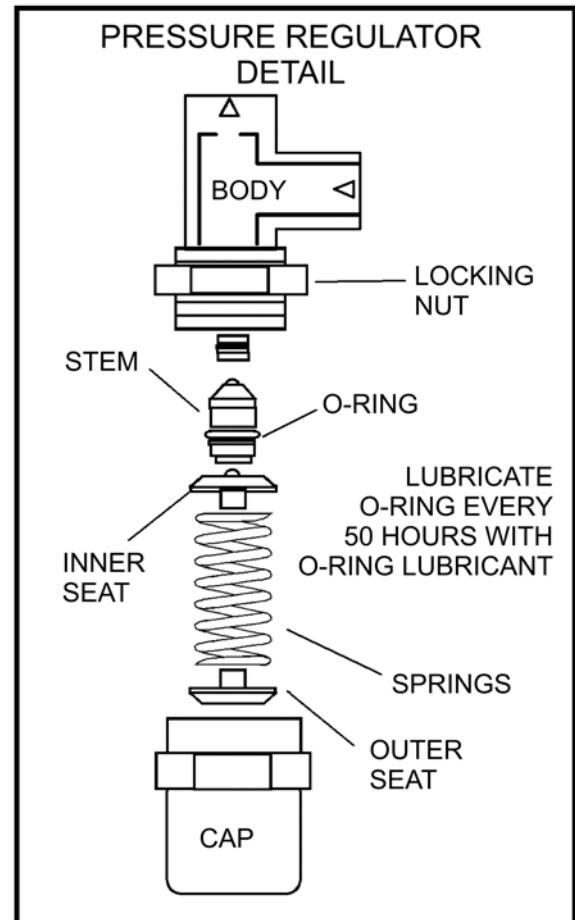

## Troubleshooting

PROBLEM	CAUSE	SOLUTION
Loss of water pump pressure.  With the cleaning tool open, the water pressure gauge reads below the normal operating pressure.	Water supply is turned off or the float valve is stuck or improperly adjusted.	Turn the water supply on or up. Check for kinks in the water supply hose. Examine the float valve and adjust or replace.
	Water pump inlet supply line is plugged or drawing air.	Examine the water inlet filter inside the water box. Remove accumulated debris and replace if required. Check for suction leaks and loose clamps or fittings. Tighten any loose fittings or clamps. Replace any ruptured hose(s).
	Improper engine speed	Using a tachometer, check the engine speed. Full throttle engine speed is 3200 RPM. Idle engine speed is 1400 RPM. Refer to the "engine speed" section for instructions on how to re-adjust.
	Pressure regulator o-rings are dry.	Lubricate o-rings, using o-ring lubricant Part #86265430, PRV NO. 05-008035.
	Pressure regulator has worn o-rings	Check o-rings. If necessary, replace.
	Pressure regulator is dirty, stuck open, or improperly adjusted.	Clean or repair regulator. Adjust to working pressure. Lubricate o-rings, using o-ring lubricant Part #86265430, PRV NO. 05-008035.
	Low pump volume. (Measure the amount of water being returned to the water box from the pressure regulator. It should fill a gallon container about every 17 seconds).	Examine the check valves, plunger cups, and cylinder head on the water pump. Repair, whenever required (refer to the water pump service manual).
	Defective water pressure gauge.	Replace gauge
	Orifice (spray nozzle) in the cleaning tool is worn, defective, or wrong size.	Replace Nozzle or change nozzle size.
	Debris clogging water lines or water inlet disconnect.	Clean or replace as needed.
	Belts loose or broken	Re-tension or replace as needed.
Loss of pump prime	Manually prime water pump.	
Loss of solution volume at cleaning tool orifice.  Water gauge reads normal.	Plugged orifice and/or screen in the cleaning tool.	Unplug or replace orifice and/or screen
	Internal block between the pressure regulator manifold and the outlet Y-strainer, or the Y-strainer screen is clogged	Inspect all lines, remove accumulated debris which is blocking proper flow. Replace any defective hoses. Remove, inspect, and clean the Y-strainer screen. De-scale unit and install a water softener, if necessary.
	Outlet check valve is plugged	Examine the check valve, remove any debris
	Defective quick-connect on one or more of the high pressure hoses.	Replace defective quick-connects(s) on high pressure hoses(s).
	Cleaning tool valve is malfunctioning.	Repair or replace valve.
	Hose inner lining is constricted.	Remove restriction or replace hose.
	Air leak in chemical supply line, priming valve or metering valve.	Check for air leaks. Replace faulty parts.

PROBLEM	CAUSE	SOLUTION
Loss of vacuum  While cleaning, the vacuum is not up to specification. Engine RPM is normal.	Vacuum gauge is giving an improper reading.	Examine the tubing between the vacuum relief valve and the vacuum gauge and remove any blockage.
	Vacuum hose(s) is damaged, causing a suction leak.	Inspect hose(s), repair or replace.
	Waste tank gaskets not sealing properly, not positioned properly	Inspect the gasket. Repair seal or replace Re-position lid(s).
	Plugged vacuum hose or vacuum plumbing between vacuum inlet and strainer basket.	Unplug vacuum hose or inlet plumbing.
	Waste tank filter or strainer basket is plugged.	Clean or replace filter. Clean strainer basket.
	Loose vacuum pump drive belts.	Tighten the drive belts
	Waste tank drain valve is damaged or left open, causing a vacuum leak.	Drain the waste tank. Close drain valve, if open. Remove the dump valve and, after inspecting, replace the defective components.
	Vacuum relief valve requires adjustment or has a vacuum leak due to damaged diaphragm.	Re-adjust the vacuum relief valve. If the vacuum does not increase, remove and inspect the relief valve diaphragm. If damaged, replace
	Vacuum exhaust heat exchangers are plugged with lint.	Remove and clean.
	Vacuum pump is worn out.	Replace the vacuum pump.
Excessive Vacuum	Improper throttle adjustment.	Adjust throttle to set desired vacuum pressure.
	Vacuum obstruction	Inspect hoses for obstructions.
	Vacuum relief valve requires adjustment.	Readjust the vacuum relief valve.
Loss of chemical  With the cleaning tool valve open, no chemical	Chemical pump is improperly primed.	Refer to chemical pump priming instructions.
	The strainer at the inlet end of the chemical inlet line is clogged	Unclog the strainer. If damaged, replace.
	Suction leak in the inlet line leading into the chemical pump.	Inspect inlet lines and flow meter for air leaks or damage and replace, if required.
	Chemical pump check valve(s) is clogged	Remove any debris from the chemical check valve(s). Replace chemical check valve(s) or seals, if necessary.
	Chemical prime/on-off valve or chemical metering valve is defective.	Replace valve(s).
	Chemical pump diaphragm is ruptured.	Disassemble the chemical pump and replace the damaged diaphragm.
	Defective cylinder in the water pump.	Measure the pump volume. If the pump volume is less than normal, refer to "Loss of Pump Volume" in the Troubleshooting section in this manual.

PROBLEM	CAUSE	SOLUTION
Chemical flow meter indicates flow with the tool valve closed	External leak in chemical piping	Tighten fittings. Re-apply thread sealant where required. If any fittings are damaged, replace.
	Outlet check valve is full of debris or damaged, not allowing it to close properly	Close the chemical valve on the instrument panel. If the flow meter does not indicate flow, remove debris or replace check valve, if necessary.
	Chemical pump diaphragm is ruptured	Close the chemical valve on the instrument panel. If the flow meter still indicates flow, replace the chemical pump diaphragm.
	Internal leak in chemical valve causing continual flow through prime tube returning to container.	Tighten valve packing nut (see "General Service Adjustments" section in this manual). Replace valve, if necessary.
Engine will not start  The engine does not turn over	Main circuit breaker on the control panel has been tripped.	After inspecting the unit to determine the cause of the tripped circuit breaker, press the reset button.
	Loose or corroded battery.	Clean, tighten, or replace the battery terminals.
	Dead battery.	Recharge or replace battery.
	Defective ignition switch.	Test ignition switch for power going into the switch. If there is power going in but NO power going out, replace the switch.
	Defective starter motor.	Test the starter motor. If necessary replace.
	Vacuum pump seized.	Refer to Tuthill Service & Repair Manual.
Starter turns over engine, but will not start	Waste tank is full.	Empty the waste tank.
	Defective fuel pump.	Replace the fuel pump.
	Loose or broken wires leading to waste tank float switch.	Repair or replace any broken electrical connections.
	Defective float switch in the waste tank.	Check switch for proper operation, replace as necessary.
	Internal engine problem.	Consult the Briggs & Stratton Vanguard Service And Repair Instruction Manual or contact your local Briggs & Stratton authorized repair center.

PROBLEM	CAUSE	SOLUTION
Engine stops running While doing normal cleaning, the engine stops running	Engine is out of gasoline	Add gasoline to the fuel tank.
	Waste tank is full	Empty waste tank.
	Main circuit breaker on the control panel has been tripped.	After inspecting the unit to determine the cause of the tripped circuit breaker, press the reset button.
	Defective fuel pump.	Replace fuel pump.
	Defective float switch inside the waste tank.	Check switch for proper operation. Replace as necessary.
	No ignition in the engine or engine is malfunctioning.	Refer to the Briggs & Stratton Engine Operation and Maintenance Manual.
Excessive heating	Flow restriction caused by hard water scaling.	Descale unit, repair or replace damaged plumbing components as necessary. Install water softener.
	Not enough water flow.	Check jet size of tool.
Heat exchanger leaks  <b>NOTE:</b> The heat exchanger will produce water condensation discharge at times during normal operation. <b>DO NOT</b> confuse this with a leak.	Engine/vacuum exhaust heat exchangers are damaged from frozen water.	Inspect heat exchangers for leaks. Visually inspect for damage. Pressure check after removing from the unit. (Maximum test pressure 1200 PSI).
Loss of temperature The heat output of the unit is LESS than normal.	Temperature relief valve on water box is stuck open.	Clean temperature relief valve and test. Replace, if necessary.
	Engine RPM is low.	Reset engine RPM.
Automatic waste pump is malfunctioning or not operating normally	Defective waste pump float switch.	Replace float switch. *
	Broken diaphragm.	Replace diaphragm.
	Weak battery.	Charge or replace battery if needed. Check charging station. *
	Pump-out circuit breaker on control panel has been tripped.	After inspecting waste pump to determine the cause of the tripped circuit breaker, press the reset button.
		* NOTE: When replacing either the pump or float switch, on Internal (in tank) Pump out, use new electrical connectors and heat shrink. Inspect connection for watertight seal.





# PARTS

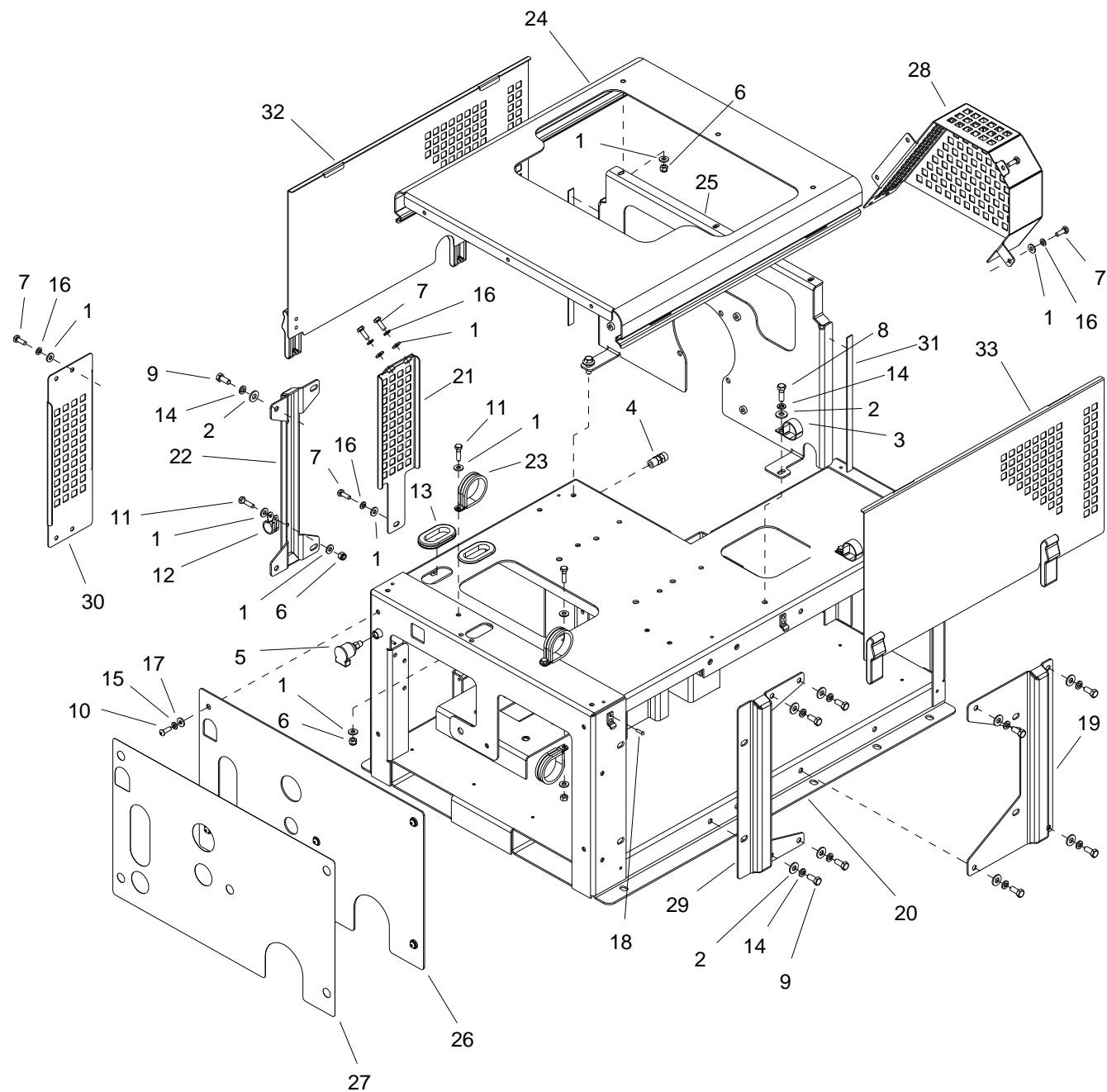

REF	PART NO.	PRV NO.	QTY	DESCRIPTION	SERIAL NO. FROM	NOTES
1	86270330	02-000066	23	FLATWASHER, 1/4		
2	86278830	02-000143	14	WASHER, 5/16 FLAT PLTD		
3	86177040	03-000149	2	CLAMP, CABLE 1-1/4 ID 5/16 BLT		
4	86177640	12-800059	1	CONN, 1/8P X 1/4POLY BR		
5	86178700	19-800075	1	CUP, OIL FILL 1/8P		
6	86005680	57047	7	NUT, 1/4-20 HEX NYLOCK		
7	86274750	70270	12	SCR, 1/4-20 X 3/4 HHCS		
8	86006750	70302	2	SCR, 5/16-18 X 1.00 HHCS GR5		
9	86006760	70305	12	SCR, 5/16-18 X 3/4 HHCS GR5		
10	86275460	70481	5	SCR, 1/4-20 X 3/4 BHCS		
11	86275570	70505	4	SCR, 1/4-20 X 1.00 HHCS GR5		
12	86233410	81270	1	CLAMP, 3/4 DIA CUSHION .406 DIA		
13	86238500	81427	2	GROMMET, 1.703IDX2.5ODX.125GRV		
14	86279130	87083	14	WASHER, 5/16 SPLIT		
15	86279400	87151	5	WASHER, 1/4 SPLIT BLK		
16	86010780	87162	12	WASHER, 1/4 SPLIT		
17	86279520	87172	5	WASHER, 1/4 X 5/8 FLAT BLK		
18	86191810	791415	8	RIVET, 5/32 OD X .251-.375 GL AL		
19	86310020	-	1	BRKT, HE SUPT		
20	86310380	-	1	ASSEMBLY, FRAME		
21	86313750	-	1	GUARD, BELT, LOWER REAR		
22	86313910	-	1	BRKT, LEFT FRAME STIFFENER		
23	86314700	-	3	CLAMP, CABLE, 1-3/4 "P" CUSHION		
24	86316050	-	1	BRKT, CENTER HOOD		
25	86316070	-	1	BRKT, REAR ENGINE SUPT		
26	86316180	-	1	PNL, LOWER FRONT, BGT		
27	86316190	-	1	LABEL, LOWER FRONT PNL, BGT		
28	86316820	-	1	GUARD, REAR BELT		
29	86316860	-	1	BRKT, FRONT HE SUPT		
30	86317250	-	1	GUARD, BELT, FRONT, BGT		
31	86318810	-	2	GASKET, HOOD VIBE DAMPNR		
32	86318880	-	1	ASSY, LEFT HOOD, BGT		
33	86318890	-	1	ASSY, RIGHT HOOD, BGT		

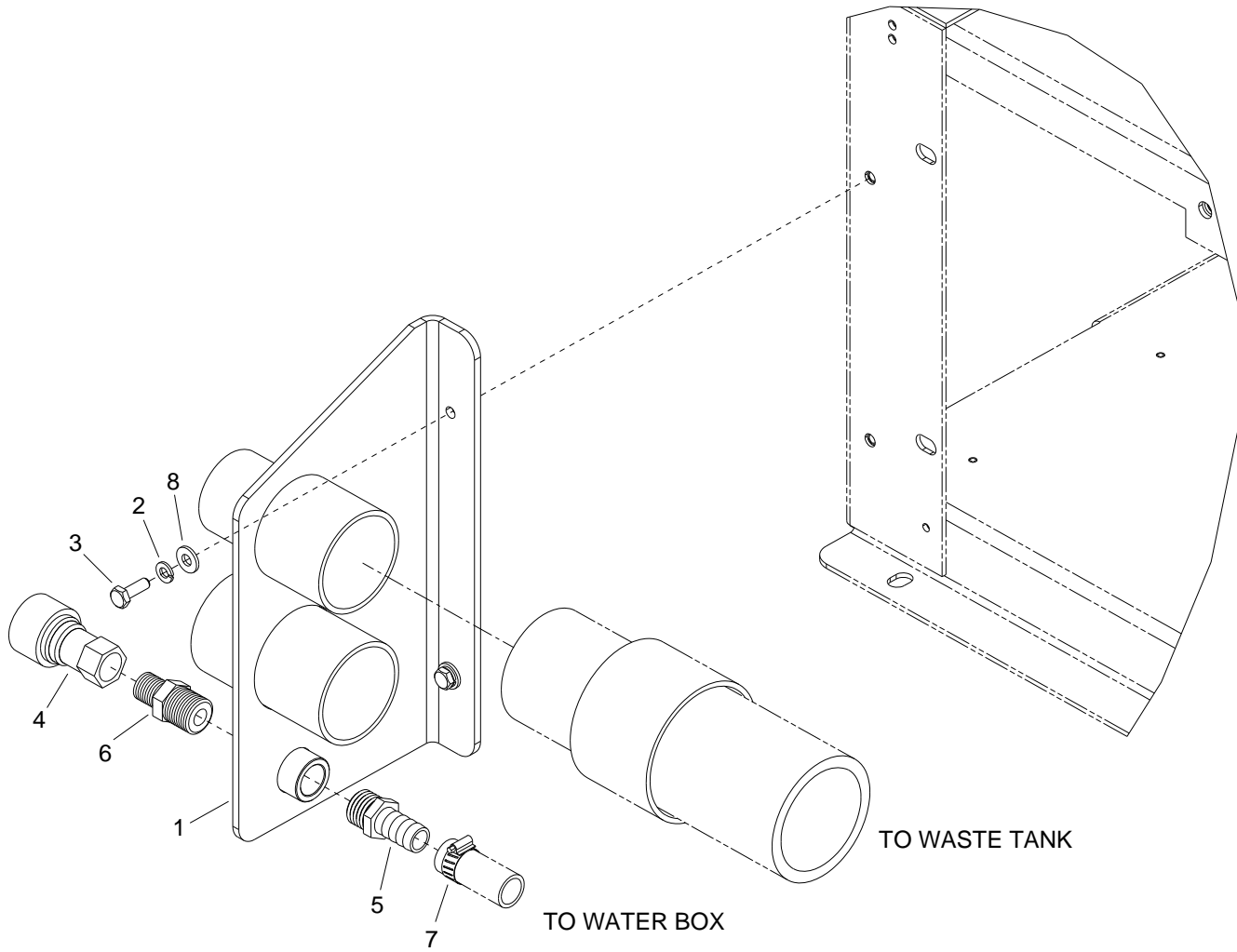

REF	PART NO.	PRV NO.	QTY	DESCRIPTION	SERIAL NO. FROM	NOTES:
1	86327760	-	1	BRKT, WTR & VAC INLET, LGT BGT		
2	86010780	87162	2	WASHER, 1/4 SPLIT LOCK		
3	86274750	70270	2	SCR, 1/4-20 X 3/4 HHCS		
4	86179710	13-806008	1	DSC, 3/8F X 3/8FP		
5	86181360	12-800269	1	FTTG, BRB 1/2P X 5/8H BR		
6	86188210	11-800354	1	NIP, 1/2 X 3/8 HEX BR		
7	86177060	03-000246	1	CLAMP, HOSE, #8 SST		
8	86270330	02-000066	2	FLATWASHER, 1/4		

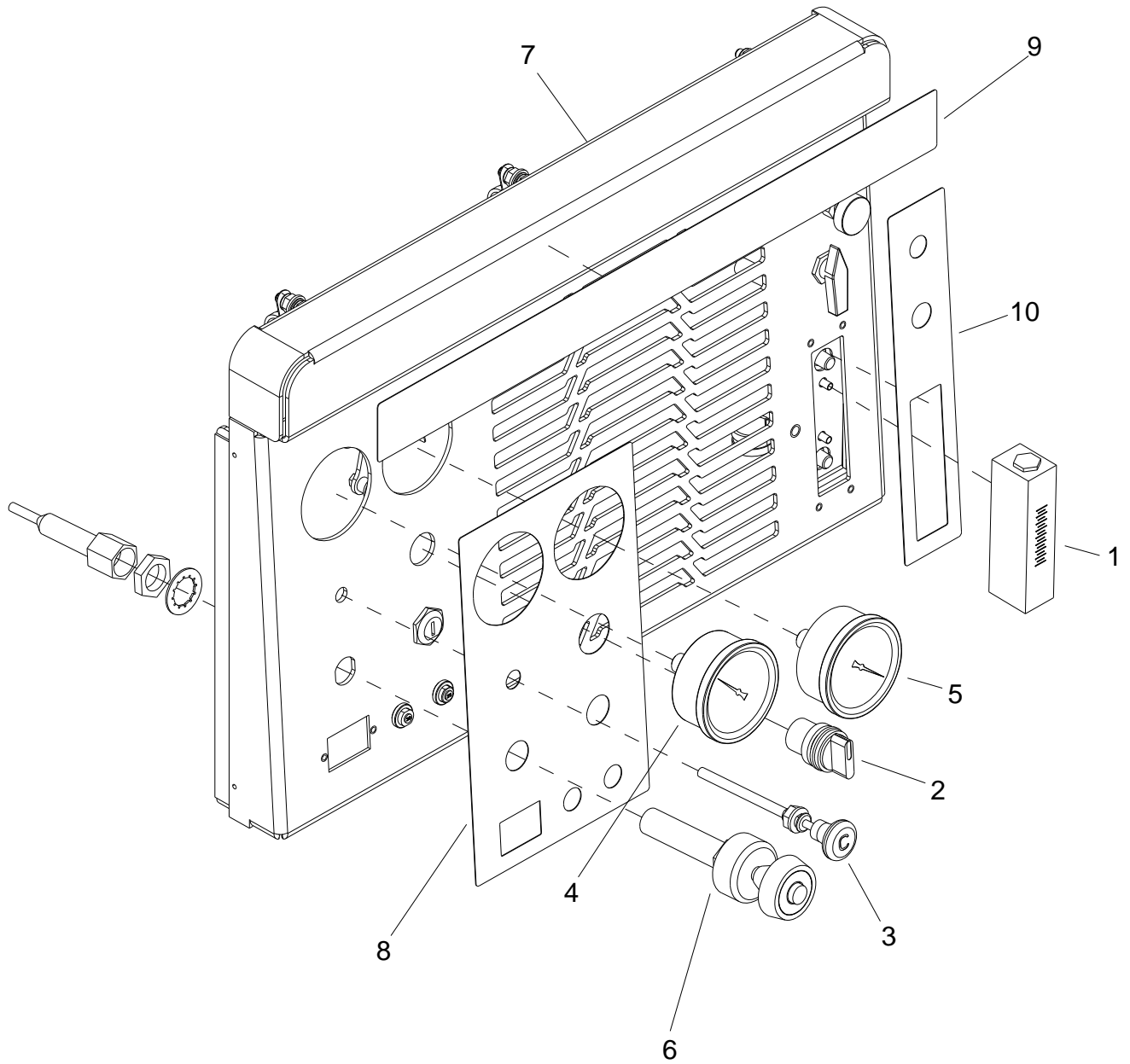

REF	PART NO.	PRV NO.	QTY	DESCRIPTION	SERIAL NO. FROM	NOTES
1	86181170	18-808513	1	FLOWMETER 1/8FP		
2	86193760	32-900206	1	SW,RTRY W/BYPASS NON-ILL		
3	86176120	49-802518	1	CABLE, CHOKE		
4	86181930	36225	1	GAUGE, 0-1500 PSI		
5	86181950	36227	1	GAUGE, VACUUM, 30" HG		
6	86177540	791081	1	CNTRL, THRTL, BLZRXL CLR/CLNR		
7	86315970	-	1	ASM, CONTROL PNL, BGT PC		
8	86316000	-	1	LABEL, CONTROL PNL, BLAZER GT		
9	86316010	-	1	LABEL, FRNT HD, BGT, PC		
10	86317220	-	1	LABEL, CHEM PNL BLZR GT		

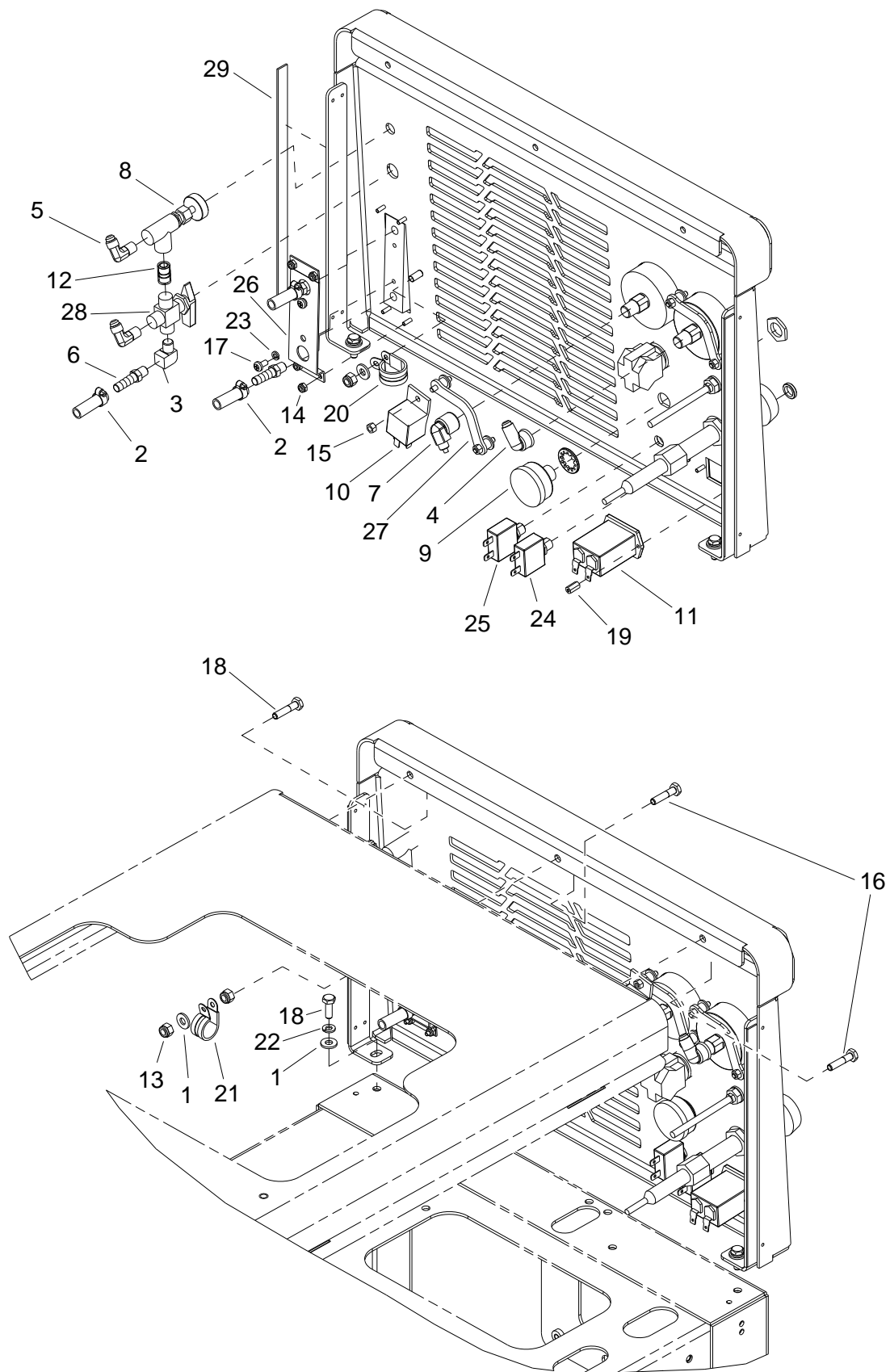



REF	PART NO.	PRV NO.	QTY	DESCRIPTION	SERIAL NO. FROM	NOTES
1	86270330	02-000066	5	FLATWASHER, 1/4		
2	86176990	03-000065	3	CLAMP, HOSE #4 SST		
3	86180140	11-800014	1	ELL, STREET 1/8 BR		
4	86180350	12-800035	1	ELL, 1/4FP X 1/4T BR		
5	86180360	12-800040	2	ELL, 1/8P X 1/4T BR		
6	86181300	12-800093	3	FTTG, BRB 1/8P X 5/16H		
7	86180380	12-800101	1	ELL, 1/4FP X 1/4POLY BR		
8	86195050	15-808106	1	VALVE, METER 1/8FP		
9	86186020	32-900174	1	KEYSWITCH		
10	86191740	35-900188	1	RELAY, ENG SHTDWN		
11	86246890	54092	1	METER,0-60VDC HOUR		
12	86247720	56032	1	NIPPLE, 1/8 CLOSE		
13	86005680	57047	6	NUT, 1/4-20 HEX NYLOCK		
14	86270920	57049	4	NUT, 6-32 HEX NYLOCK SS		
15	86136310	57086	4	NUT, M5 X 4.7 HEX NYLOCK		
16	86273820	70019	2	SCR, 1/4-20 X 1.25 HHCS SS		
17	86274290	70162	2	SCR, 10-32 X 3/8 PPHMS SS		
18	86274750	70270	3	SCR, 1/4-20 X 3/4 HHCS		
19	86255920	73811	2	STANDOFF, 6-32 X 1/2 HEX NYL		
20	86233390	80887	1	CLAMP, 7/8 DIA P CUSHIONED		
21	86233410	81270	2	CLAMP, 3/4 DIA CUSHION .406 DIA		
22	86010780	87162	2	WASHER, 1/4 SPLIT		
23	86279470	87165	2	WASHER, #10 SPLIT		
24	86175610	140625	1	BRKR, CIRCUIT, 30A		
25	86175620	140654	1	BRKR, CIRCUIT 25A		
26	86017360	140675	1	BRKT, FLOW METER		
27	86175680	140702	2	BRKT, WIKA MOUNTING		
28	86297070	-	1	VALVE, 3-WAY BALL 1/8P		
29	86318810	-	2	GASKET, HOOD VIBE DAMPNR		

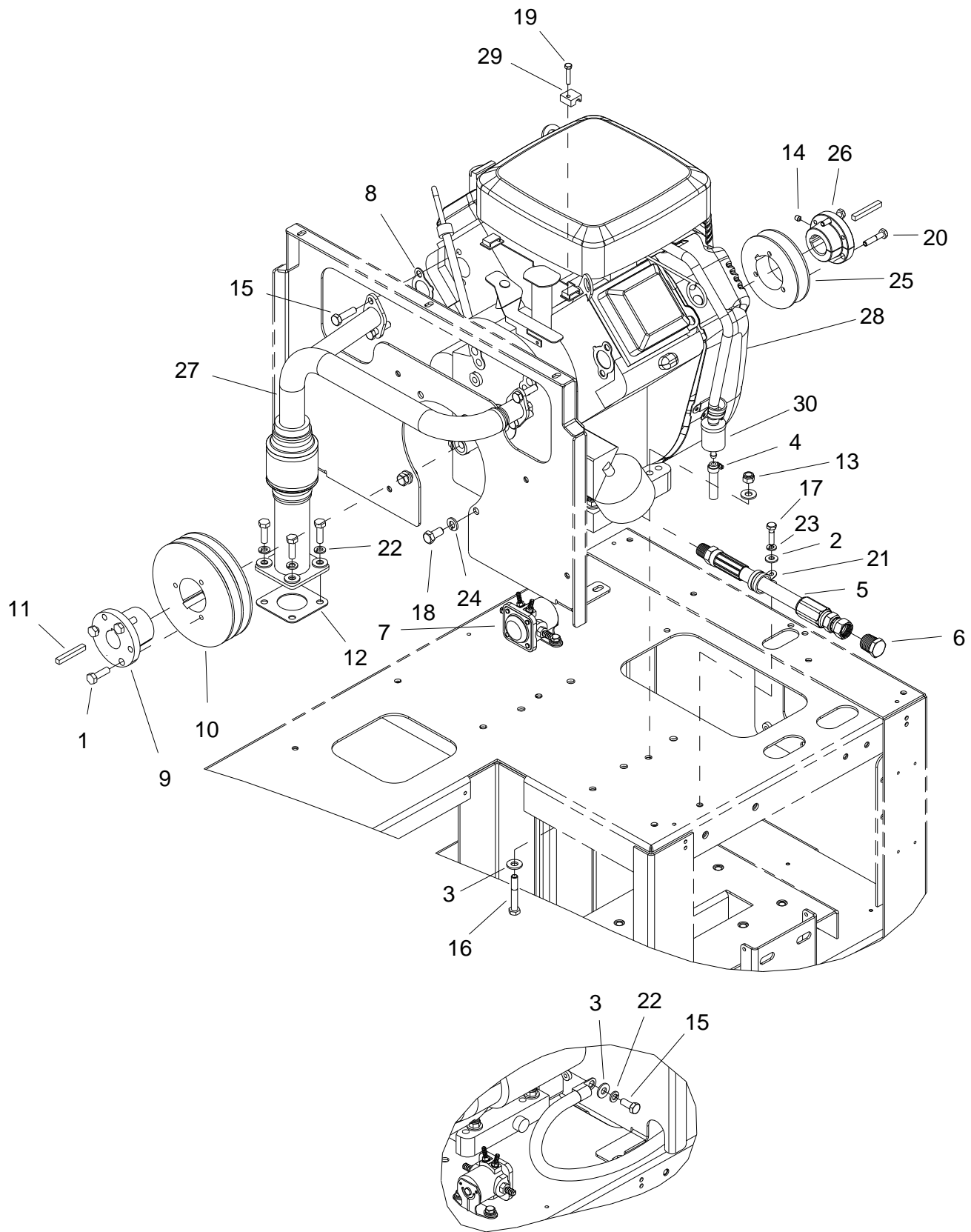

REF	PART NO.	PRV NO.	QTY	DESCRIPTION	SERIAL NO. FROM	NOTES
1	86273440	00-000340	7	SCR, MACH 5/16-18 X 1" GR8		
2	86270330	02-000066	3	FLATWASHER, 1/4		
3	86278830	02-000143	13	WASHER, 5/16 FLAT PLTD		
4	86176990	03-000065	2	CLAMP, HOSE #4 SST		
5	86183600	10-805291	1	HOS, 3/8 X 10 (3/8P X 1/2T)		
6	86190550	12-800062	1	PLUG, 1/2T		
7	86192870	35-901002	1	SOLENOID, STARTER		
8	86181790	42-902174	2	GASKET, EXHAUST MNFLD		
9	86185330	44-802202	1	HUB, P1 X 1		
10	86191030	44-802212	1	PULLEY, 2TA54		
11	86049230	54-500412	2	KEY, 1/4 SQ X 1.88		
12	86182290	35275	1	GSKT, EXH, KUB, D902/WG972		
13	86005750	57113	4	NUT, 5/16-18 HEX NYLOCK		
14	86277930	70119	1	SCR, 1/4-20 X 3/8 SSSCU DL		
15	86136640	70262	5	SCR, M8 X 20 HHMS		
16	86274900	70320	4	SCR, 5/16-18 X 2.00 HHCS GR5		
17	86275570	70505	3	SCR, 1/4-20 X 1.00 HHCS GR5		
18	86006920	70507	4	SCR, 3/8-16 X 3/4 HHCS GR5		
19	86277890	70856	1	SCR, M5 - 8 X 25MM STL, ZNC		
20	86277680	70937	3	SCR, 1/4-20 X 1-1/4 HXHD GR8		
21	86233390	80887	2	CLAMP, 7/8 DIA P CUSHIONED		
22	86279130	87083	5	WASHER, 5/16 SPLIT		
23	86010780	87162	3	WASHER, 1/4 SPLIT		
24	86010790	87163	4	WASHER, 3/8 SPLIT		
25	86191280	790719	1	PULLEY, 1B36SH		
26	86185400	790720	1	HUB, SH1		
27	86316380	-	1	TUBE, EXHAUST, B&S 18HP		
28	86317390	-	1	ENG, B&S, 18HP W/FRNT SHFT		
29	86318050	-	1	CLAMP, THROTTLE CABLE		
30	86318330	-	1	FILTER, FUEL, 1/4" HOSE		

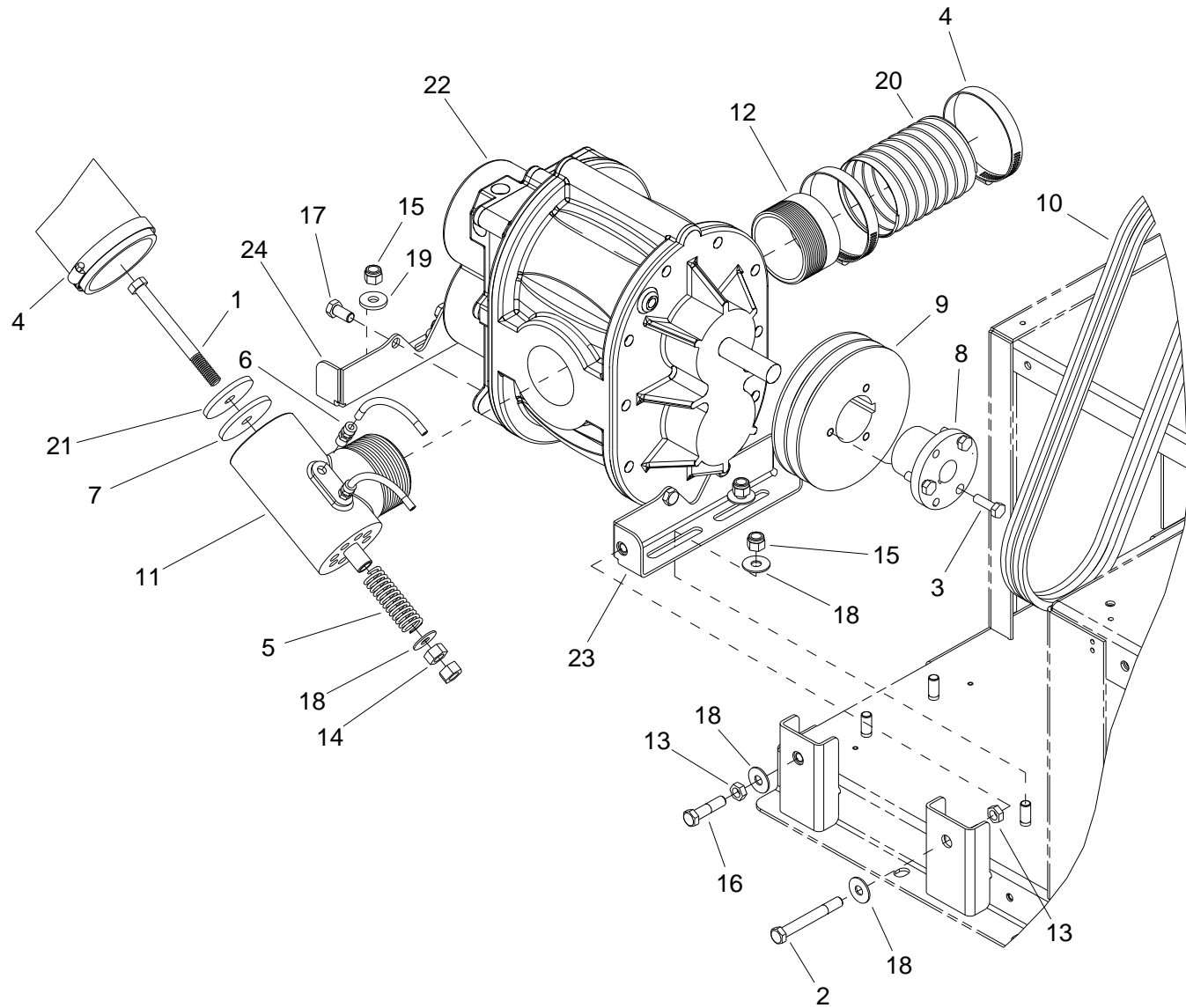

REF	PART NO.	PRV NO.	QTY	DESCRIPTION	SERIAL NO. FROM	NOTES
1	86273320	00-000284	1	SCR, CAP 7/16-14 x 4 HXHD		
2	86273420	00-000336	1	SCR,CAP 3/8-16x3 ALL THD		
3	86273440	00-000340	3	SCR, MACH 5/16-18 X 1" GR8		
4	86177010	03-000112	3	CLAMP, HOSE #48		
5	86193230	04-000091	1	SPRING, VAC REL VLV		
6	86177640	12-800059	2	CONN, 1/8P X 1/4POLY BR		
7	86179580	43-807074	1	DIAPHRAM, VAC REL VLV		
8	86185320	44-802196	1	HUB, P1 X 7/8		
9	86191030	44-802212	1	PULLEY, 2TA54		
10	86175030	44-802250	2	BELT, AX38 GOODYEAR MATCH		
11	86180600	52-501573	1	ELL, VAC REL VLV		
12	86188500	54-501593	1	NIP, VAC EXH OUTL		
13	86005690	57085	2	NUT, 3/8-16 HEX JAM		
14	86271070	57114	2	NUT, 7/16-14 HEX		
15	86005770	57119	4	NUT, 3/8-16 HEX NYLOCK		
16	86274660	70255	1	SCR, 3/8-16 X 1.50 HHCS GR5		
17	86006920	70507	4	SCR, 3/8-16 X 3/4 HHCS GR5		
18	86279510	87171	5	WASHER, 3/8 X 1 FLAT NP		
19	86310690	-	2	WASH,3/8ID X 1.0OD X 1/8THK SS		
20	86311490	-	1	TUBING, FLEX, BLWR TO MFLR		
21	86311600	-	1	WASHER, VAC REL VLV, #4VAC		
22	86316450	-	1	PUMP, VAC, TUTHILL		
23	86316600	-	1	BRKT, FRONT BLOWER MTG		
24	86316610	-	1	BRKT, REAR BLOWER MTG		

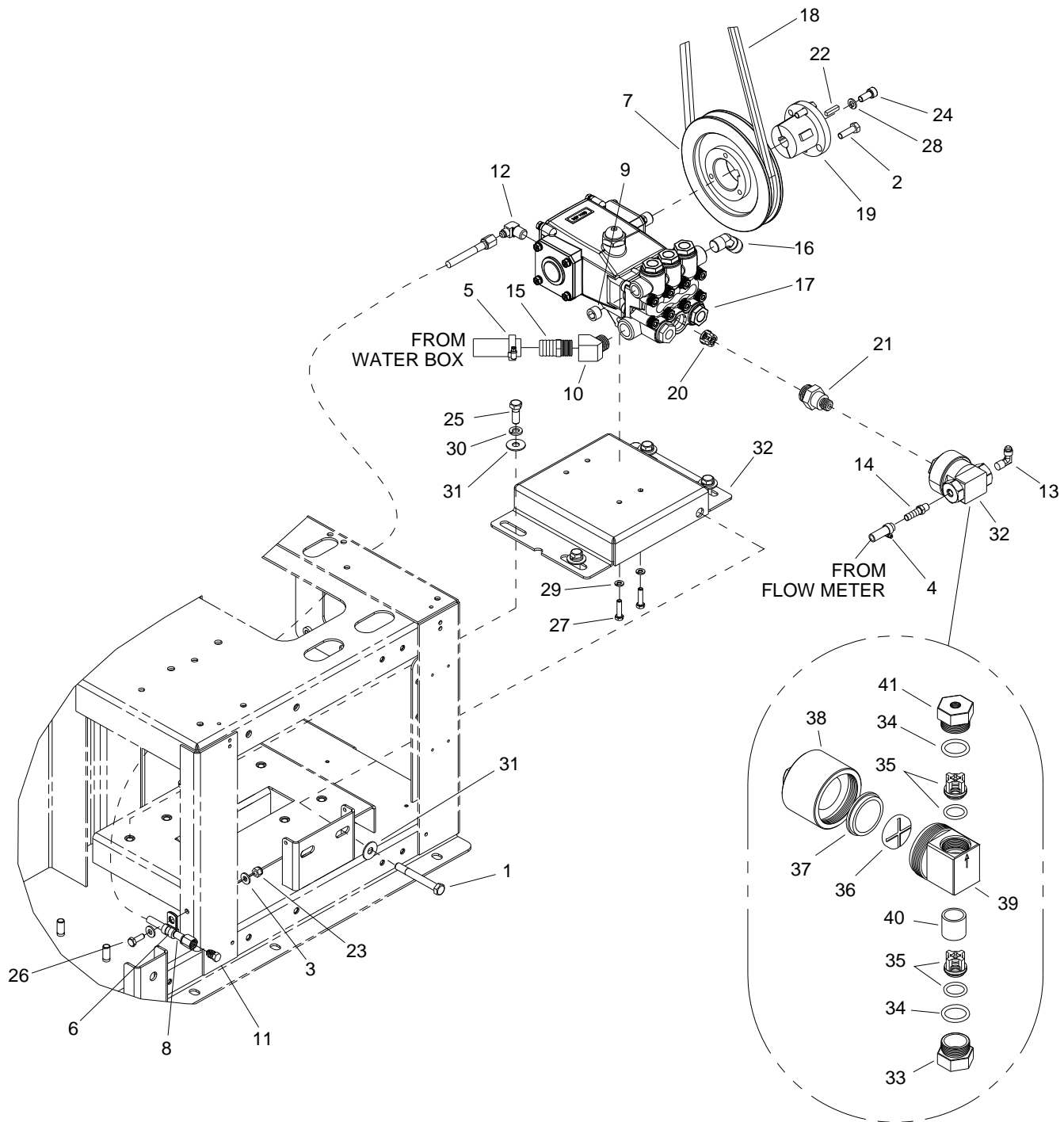

REF	PART NO.	PRV NO.	QTY	DESCRIPTION	SERIAL NO. FROM	NOTES
1	86273420	00-000336	1	SCR,CAP 3/8-16X3 ALL THD		
2	86273440	00-000340	3	SCR, MACH 5/16-18 X 1" GR8		
3	86270330	02-000066	2	FLATWASHER, 1/4		
4	86176990	03-000065	1	CLAMP, HOSE #4 SST		
5	86177020	03-000113	1	CLAMP, HOSE #12 SST		
6	86177320	03-000249	1	CLMP, CABL 1/4 ID 3/8BLT		
7	86317380	-	1	PULLEY, 1TB62		
8	86183700	10-805322	1	HOS, 3/16X19(1/4FT BS)MET		
9	86190520	11-800224	1	PLUG, 3/8 SOCHD BR		
10	86180230	11-800299	1	ELL, STREET 1/2 45 DEG		
11	86190540	12-800029	1	PLUG, 1/4T BR		
12	86180340	12-800031	1	ELL, 1/4P X 1/4T BR		
13	86180360	12-800040	1	ELL, 1/8P X 1/4T BR		
14	86181300	12-800093	1	FTTG, BRB 1/8P X 5/16H		
15	86181370	12-800278	1	FTTG, BRB 1/2P x 3/4H BR		
16	86180450	12-800347	1	ELL, 3/8P X 1/2T 45 DEG. BR		
17	86190670	41-809153	1	PMP, WTR CAT 3CP1140		
18	86174960	44-802220	1	BELT, AX37 GOODYEAR MATCH		
19	86185370	52-501925	1	HUB, PUMP WATER		
20	86191780	52-809123	1	RETAIN, VALVE SPRING		
21	86173750	52-809125	1	ADPT, CAT CHEM PMP		
22	86049240	54-500680	1	KEY, 3/16 SQ X 7/8		
23	86005680	57047	1	NUT, 1/4-20 HEX NYLOCK		
24	86274650	70254	1	SCR, M8 X 18 SHCS PLTD		
25	86006740	70266	4	SCR, 3/8-16 X 1.00 HHCS GR5		
26	86274750	70270	1	SCR, 1/4-20 X 3/4 HHCS		
27	86276570	70691	4	SCR, M6 X 25 HHCS		
28	86279130	87083	1	WASHER, 5/16 SPLIT		
29	86279140	87085	4	WASHER, M6 SPLIT LOCK DIN127B		
30	86010790	87163	4	WASHER, 3/8 SPLIT		
31	86279510	87171	5	WASHER, 3/8 X 1 FLAT NP		
32	86328800	-	1	BRKT, WTR PMP MTG, BGT		
33	86195100	65245	2	VALVE CAP, 303 SST, INPUT		
34	86189290	65249	2	O-RING, DURO,.862ID X .103CS		
35	86195110	65247	2	VALVE KIT, ASM, CHEM, PULSE PUMP		
36	86249220	65252	1	PLASTIC DISC		
37	86179550	42-809047	1	DIAPHRAGM, CHEM PUMP		
38	86194630	65250	1	PULSE PUMP, TOP COVER INLET		
39	86191340	65253	1	PULSE PUMP, BODY		
40	86192920	65246	1	SPACER RING, 303 SST		
41	86195120	65248	1	VALVE CAP, 303 SST, OUTPUT		

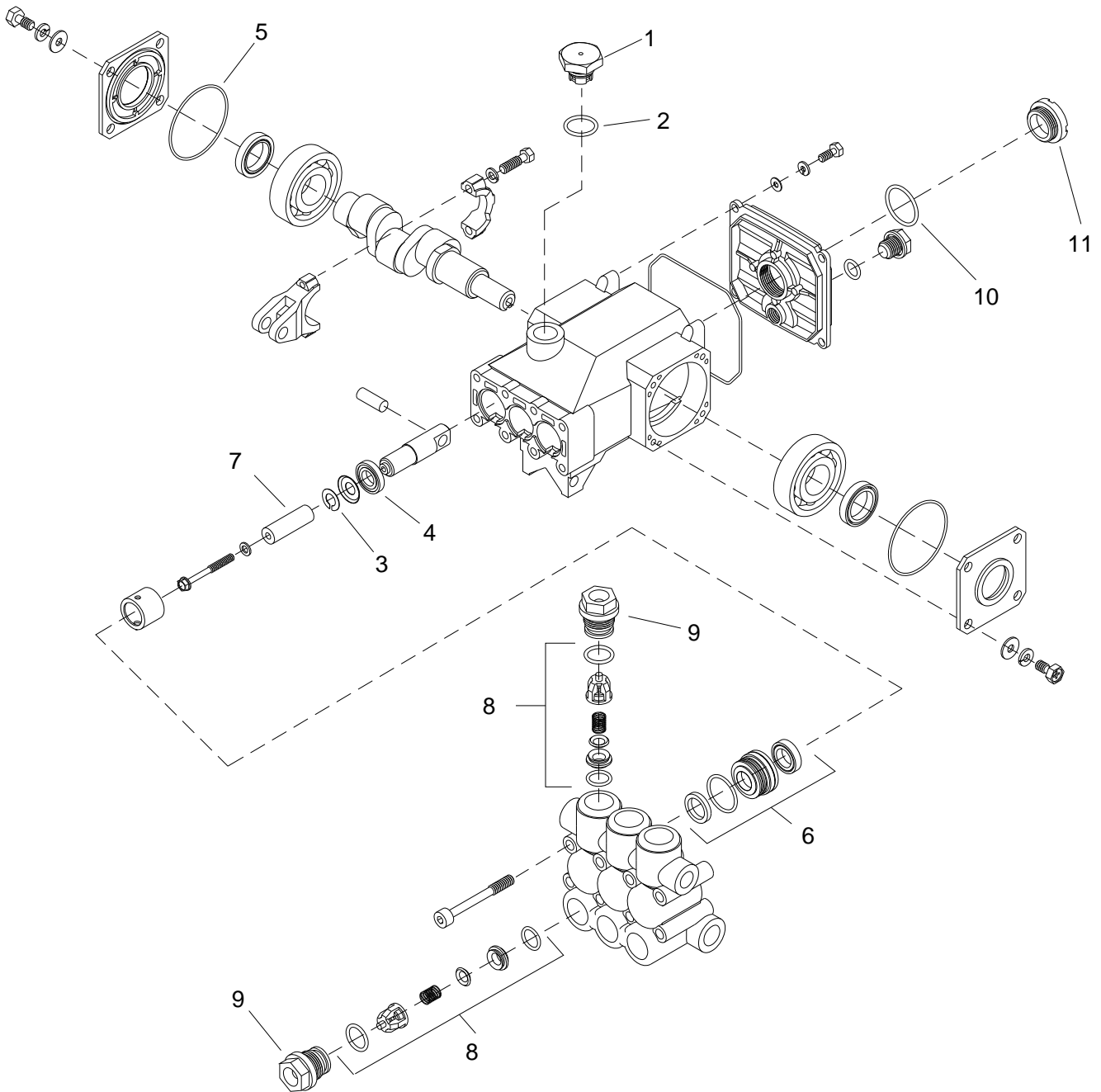



REF	PART NO.	PRV NO.	QTY	DESCRIPTION	SERIAL NO. FROM	NOTES:
1	86176520	42-809238	1	CAP, OIL FILLER		
2	86189200	42-809239	1	O-RING, OIL FILL CAP		
3	86195580	42-809249	1	WASHER, KEYHOLE M18		
4	86192260	42-809409	1	SEAL, OIL CRANKCASE		
5	86189210	42-809394	2	O-RING, BEARING CVR		
6	86186090	42-809410	1	KIT, SEAL		ORDER 1 EACH
7	86190600	42-809408	1	PLUNGER		
8	86286260	66-950441	-	KIT, VLV CAT 3CP1140, 33258		ORDER 1 EACH TO REPLACE ALL VALVES
9	86190560	42-809404	2	PLUG, VALVE		
10	86181800	43-807063	1	GASKET, OIL GAUGE		
11	86181970	42-902380	1	GAUGE, OIL LEVEL		

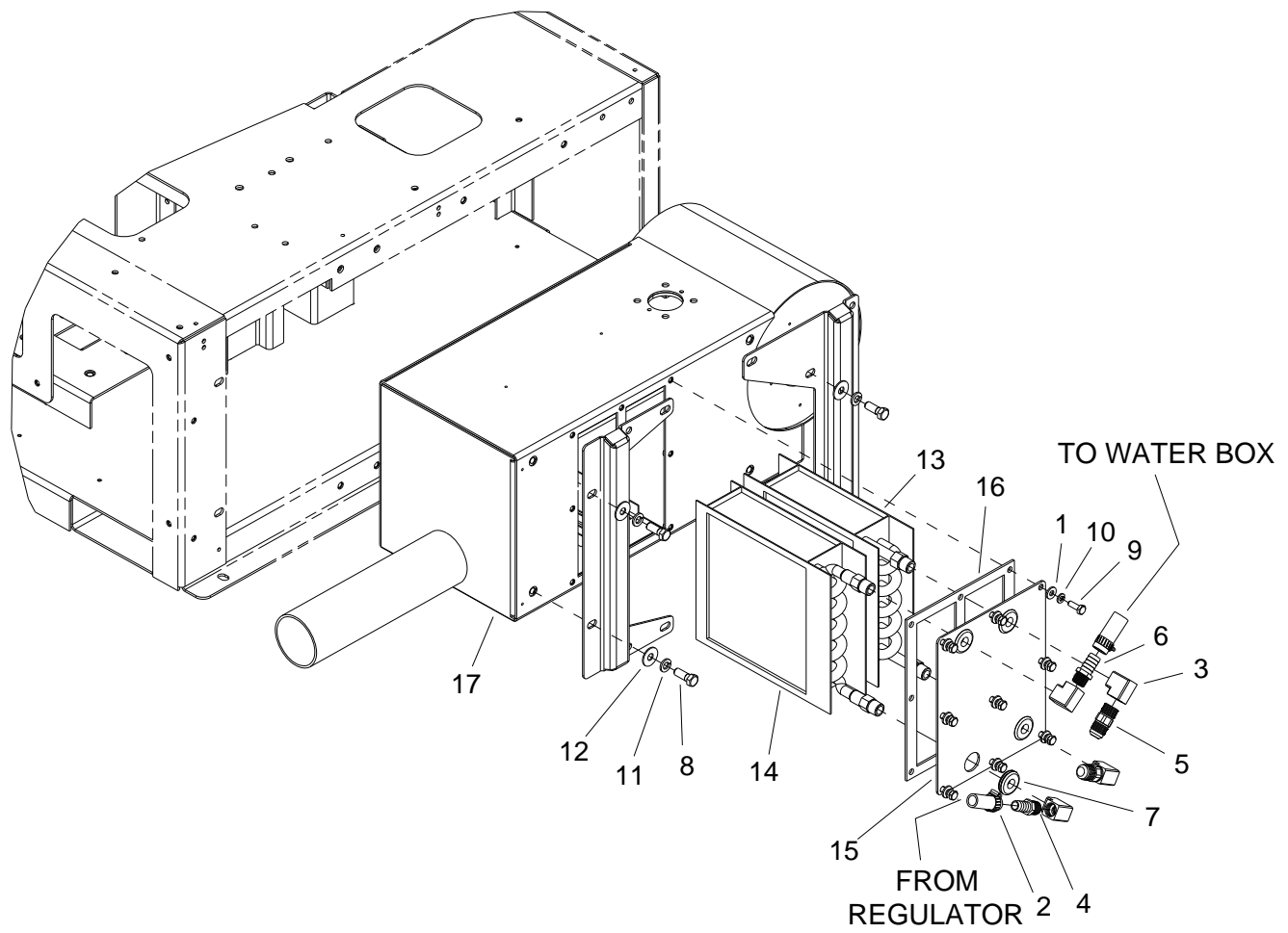

REF	PART NO.	PRV NO.	QTY	DESCRIPTION	SERIAL NO. FROM	NOTES
1	83270330	02-000066	9	FLATWASHER, 1/4		
2	86177060	03-000246	2	CLAMP, HOSE, #8 SST		
3	86180220	11-800276	4	ELL, 3/8 BR		
4	86181330	12-800161	1	FTTG, BRB 3/8PX1/2H BR		
5	86177700	12-800282	2	CONN, 3/8P X 1/2T BR		
6	86181400	12-800345	1	FTTG, BRB 3/8P x 5/8H BR		
7	86182190	36238	4	GROMT, 1/2ID X 1-1/4OD 1/8G 5/16W		
8	86006740	70266	4	SCR, 3/8-16 X 1.00 HHCS GR5 PLT		
9	86274750	70270	9	SCR, 1/4-20 X 3/4 HHCS		
10	86010780	87162	9	WASHER, 1/4 SPLIT LOCK PLTD		
11	86010790	87163	4	WASHER, 3/8 SPLIT LOCK PLTD		
12	86279510	87171	4	WASHER, 3/8 X 1 FLAT		
13	86043150	790388	1	ASSEMBLY, HEATER CORE SS		
14	86318840	-	1	ASSY, HEATER CORE COPPER, GT		
15	86308920	-	1	PLATE, HEATER CORE COVER		
16	86308930	-	1	GASKET, HEATER CORE COVER		
17	86316410	-	1	HOUSING, VAC HE BOX		

# Pressure Regulator & Temperature Control Valve

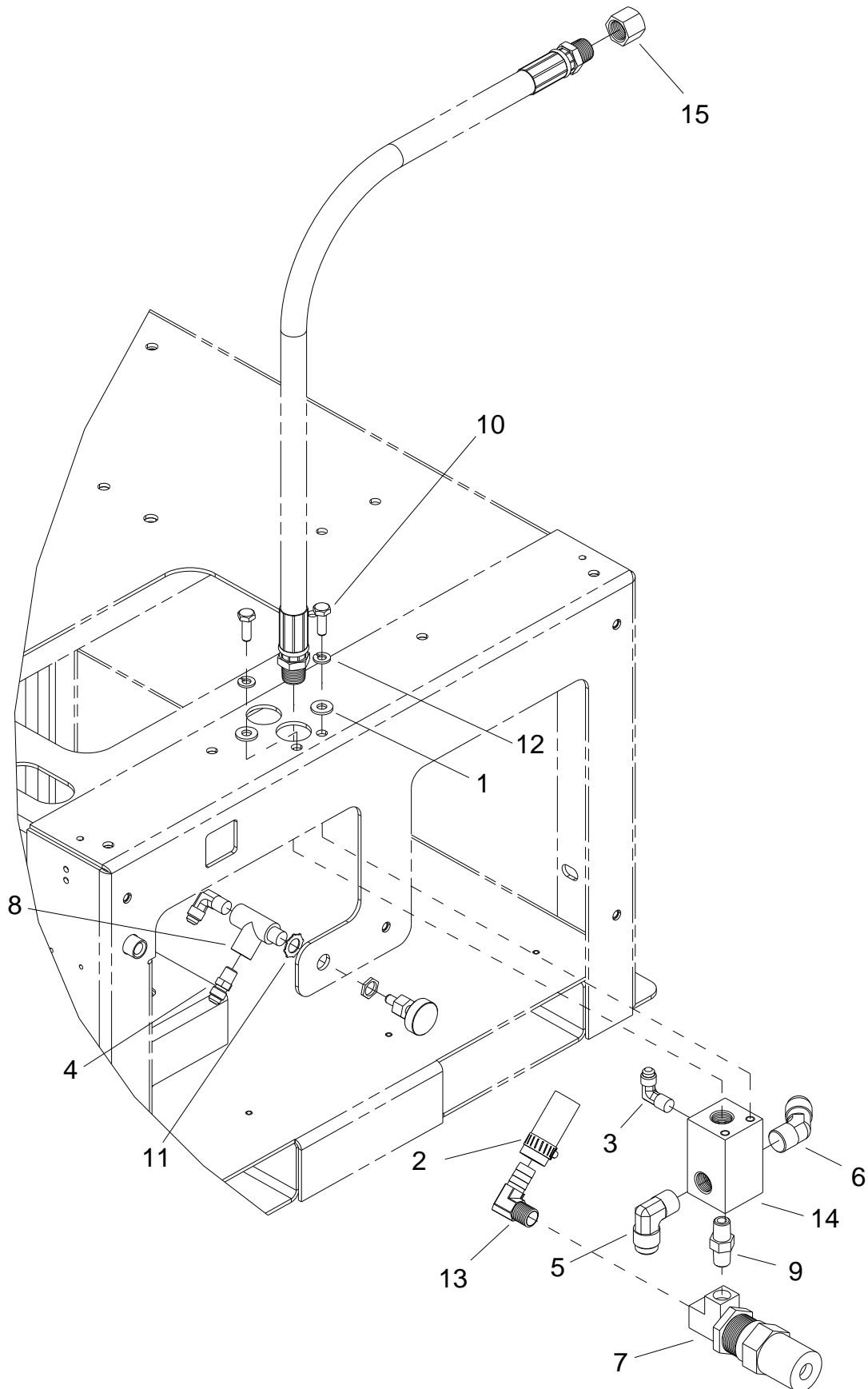

*Pressure Regulator & Temperature Control Valve*

REF	PART NO.	PRV NO.	QTY	DESCRIPTION	SERIAL NO. FROM	NOTES:
1	86270330	02-000066	2	FLATWASHER, 1/4		
2	86177060	03-000246	1	CLAMP, HOSE, #8 SST		
3	86180360	12-800040	2	ELL, 1/8P X 1/4T BR		
4	86177660	12-800065	1	CONN, 1/8P X 1/4T		
5	86180410	12-800225	1	ELL, 3/8P X 1/2T BR		
6	86180450	12-800347	1	ELL, 3/8P X 1/2T 45 DEG. BR		
7	86191630	15-808081R	1	REG, PRESS W/DUAL SPRING		
8	86195050	15-808106	1	VALVE, METERING 1/8FP		
9	86247680	56015	1	NIPPLE, 1/4 HEX		
10	86273780	70015	2	SCR, 1/4-20 X 3/4 HHCS SS		
11	86278970	87012	1	WASHER, 7/16 EXT STAR		
12	86010780	87162	2	WASHER, 1/4 SPLIT LOCK		
13	86180040	790722	1	ELBOW, 1/4MPX1/2H 90DEG		
14	86312440	-	1	MNFLD, PRESSURE REG		
15	86313740	-	1	CAP, STEEL, 3/8-18FPT		

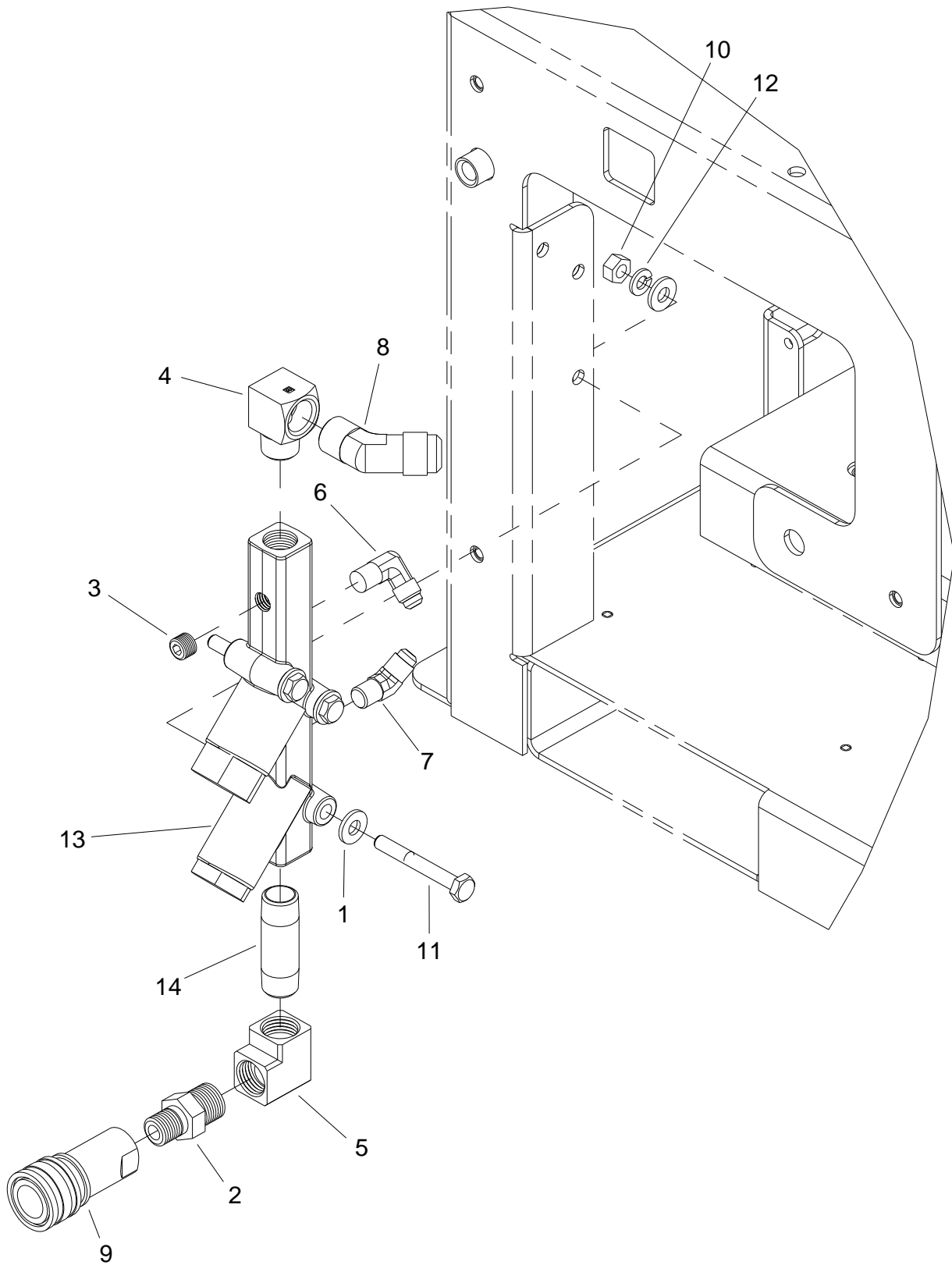

REF	PART NO.	PRV NO.	QTY	DESCRIPTION	SERIAL NO. FROM	NOTES
1	86270330	02-000066	6	FLATWASHER, 1/4		
2	86188130	11-800151	1	NIPPLE, 3/8M X 1/4M		
3	86190180	11-800206	1	PLG, 1/8 SOCHD BR		
4	86180210	11-800275	1	ELL, ST 3/8 BR		
5	86180220	11-800276	1	ELL, 3/8 BR		
6	86180360	12-800040	1	ELL, 1/8P X 1/4T BR		
7	86180420	12-800261	1	ELL, 1/8P X 1/4T 45 DEG		
8	86180450	12-800347	1	ELL, 3/8P X 1/2T 45 DEG. BR		
9	86002450	22015	1	COUPLER, 1/4 QD		
10	86270770	57006	3	NUT, 1/4-20 HEX		
11	86273850	70022	3	SCR, 1/4-20 X 2.00 HHCS SS		
12	86010780	87162	3	WASHER, 1/4 SPLIT LOCK PLTD		
13	86311640	-	1	ASSY, SOLUTION MANIFOLD, 6.63		
14	86312630	-	1	NIPPLE, 3/8 X 2 BR		

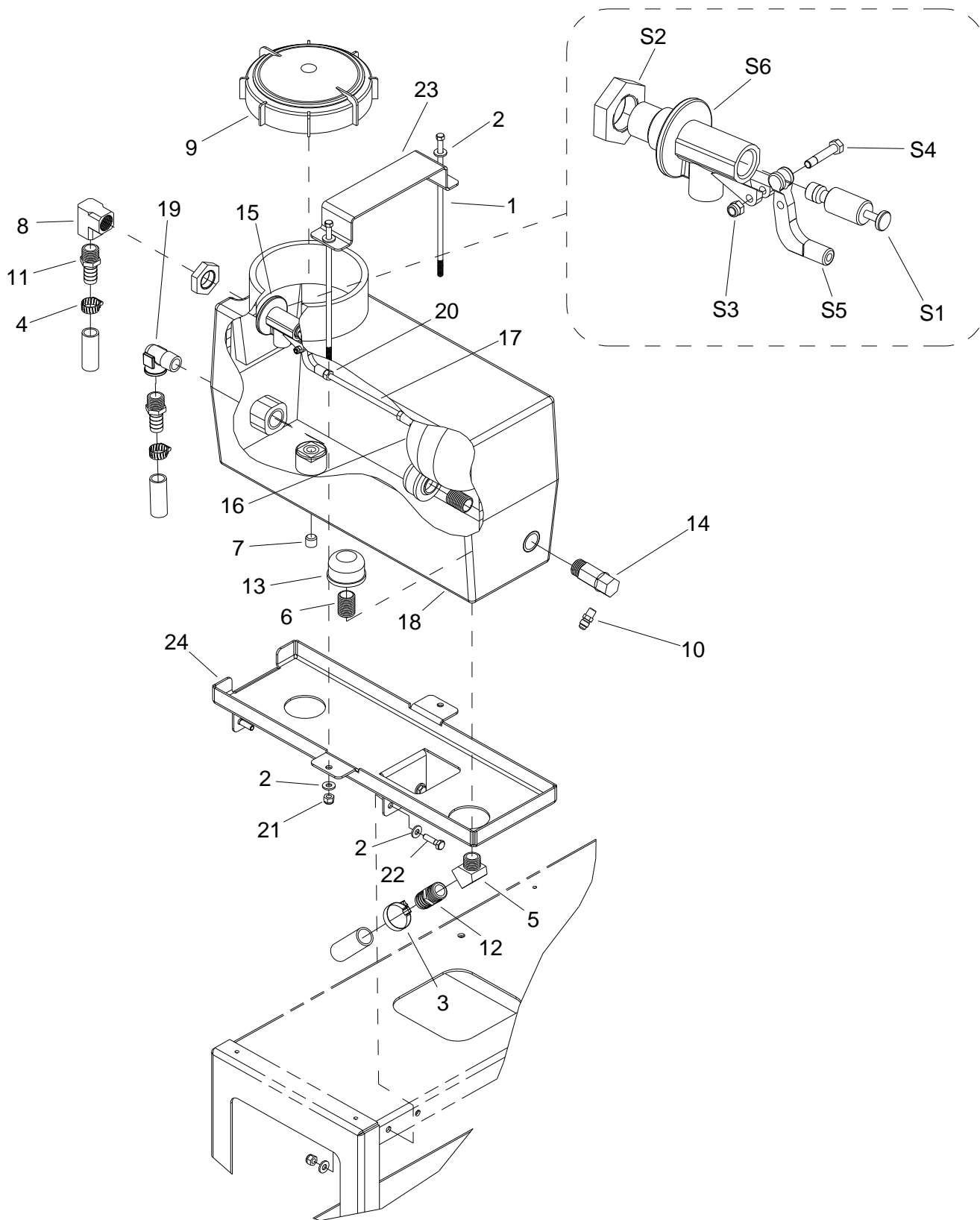



REF	PART NO.	PRV NO.	QTY	DESCRIPTION	SERIAL NO. FROM	NOTES:
1	86273410	00-000335	2	SCR, CAP 1/4-20 X 8 HXHD		
2	86270330	02-000066	12	FLATWASHER, 1/4		
3	86177020	03-000113	1	CLAMP, HOSE #12 SST		
4	86177060	03-000246	2	CLAMP, HOSE, #8 SST		
5	86180230	11-800299	1	ELL, STREET 1/2 45 DEG		
6	86188180	11-800300	2	NIP, 1/2 CL		
7	86272720	11-800345	1	PLG, 1/4 SOCHD BRASS		
8	86180250	11-800361	1	ELL, 1/2 BR		
9	86176400	11-800432	1	CAP, WATER BOX		
10	86177660	12-800065	1	CONN, 1/8P X 1/4T		
11	86181360	12-800269	2	FTTG, BRB 1/2P X 5/8H BR		
12	86181370	12-800278	1	FTTG, BRB 1/2P x 3/4H BR		
13	86193440	14-806540	2	STRAINER, SUC END 1/2FP		
14	86195340	15-808075	1	VLV, TEMP REL 145DEG		
15	86195060	15-808110	1	VALVE, FLOAT, TM		
16	86174540	19-807014	1	BALL, FLOAT		
17	86181150	54-501715	1	ROD, FLOAT 1/4-20 X 6" SS		
18	86187820	58-500781	1	MOLDING, WATER BOX		
19	86180570	31098	1	ELL, STREET 1/2 BR FORGED		
20	86270770	57006	2	NUT, 1/4-20 HEX		
21	86005680	57047	6	NUT, 1/4-20 HEX NYLOCK		
22	86275570	70505	4	SCR, 1/4-20 X 1.00 HHCS GR5		
23	86308940	-	1	BRKT, WTR BOX HOLDDOWN		
24	86309000	-	1	BRKT, WTR BOX MTG		
-	-	-	-	-		
S1	86189870	16-808219	1	PISTON, FLOAT VLV		
S2	86189010	52-501706	1	NUT, FLOAT VALVE		
S3	86024750	94028	1	NUT, M5 HEX NYLOCK, SS		
S4	86308950	-	1	SCR, HHSS, M5X20 SS		
S5	86309140	-	1	ARM, PIVOT, FLOAT VLV		
S6	86309160	-	1	BDY, FLOAT VALVE		

# 60 Gallon Waste Tank

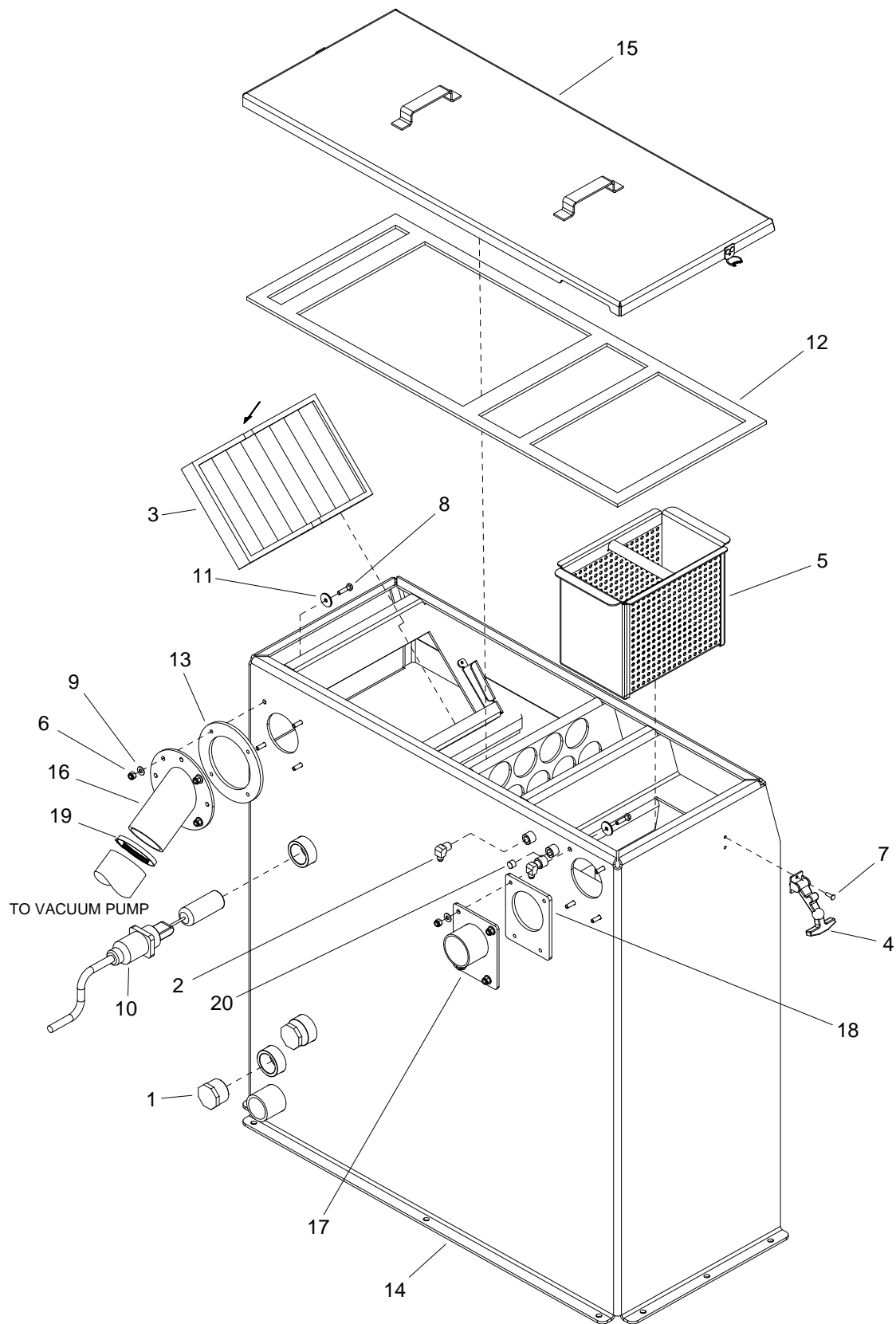

REF	PART NO.	PRV NO.	QTY	DESCRIPTION	SERIAL NO. FROM	NOTES
-	86329060	-	1	KIT, WASTE TANK, 60G, LGT/ BGT PC		COMPLETE
1	86190530	11-800402	2	PLUG, 1-1/4 HXHD PVC		
2	86180340	12-800031	2	ELL, 1/4P X 1/4T BR		
3	86193540	14-806569	1	STRNR, WST TNK, RECT, 1.5		
4	86186860	46-802510	2	LATCH, DRAW 2-7/8 SST		
5	86043190	56-501793	1	STRAINER BOWL, AVENGER 450		
6	86005810	57245	8	NUT, 1/4-20 HEX NYLOCK SS		
7	86273020	67006	8	RIVET, 3/16 OD X 5/8 AL		
8	86273810	70018	8	SCR, 1/4-20 X 1 HHCS SS		
9	86010630	87013	8	WASHER, 1/4 X 5/8 FLAT SS		
10	86193870	791066	1	ASSY, LVL SENS SHTOF SW		
11	86202240	-	8	WASHER, SEAL 1/4 X 1 OD SS		
12	86318530	-	1	GASKET, WASTE TANK LID		
13	86318560	-	1	GASKET, VAC OUTLET		
14	86320940	-	1	TANK, WASTE, 60G PC		
15	86320990	-	1	LID, WST TNK, 60G PC		
16	86321040	-	1	OUTLET, VACUUM, 2-7/8", PC		
17	86323650	-	1	INLET, 2-1/2" VACUUM, PC		
18	86323700	-	1	GASKET, VAC INLET		
19	86177010	03-000112	1	CLAMP, HOSE #48		
20	86272720	11-800345	1	PLG, 1/4 SOCHD BRASS		

# 100 Gallon Waste Tank

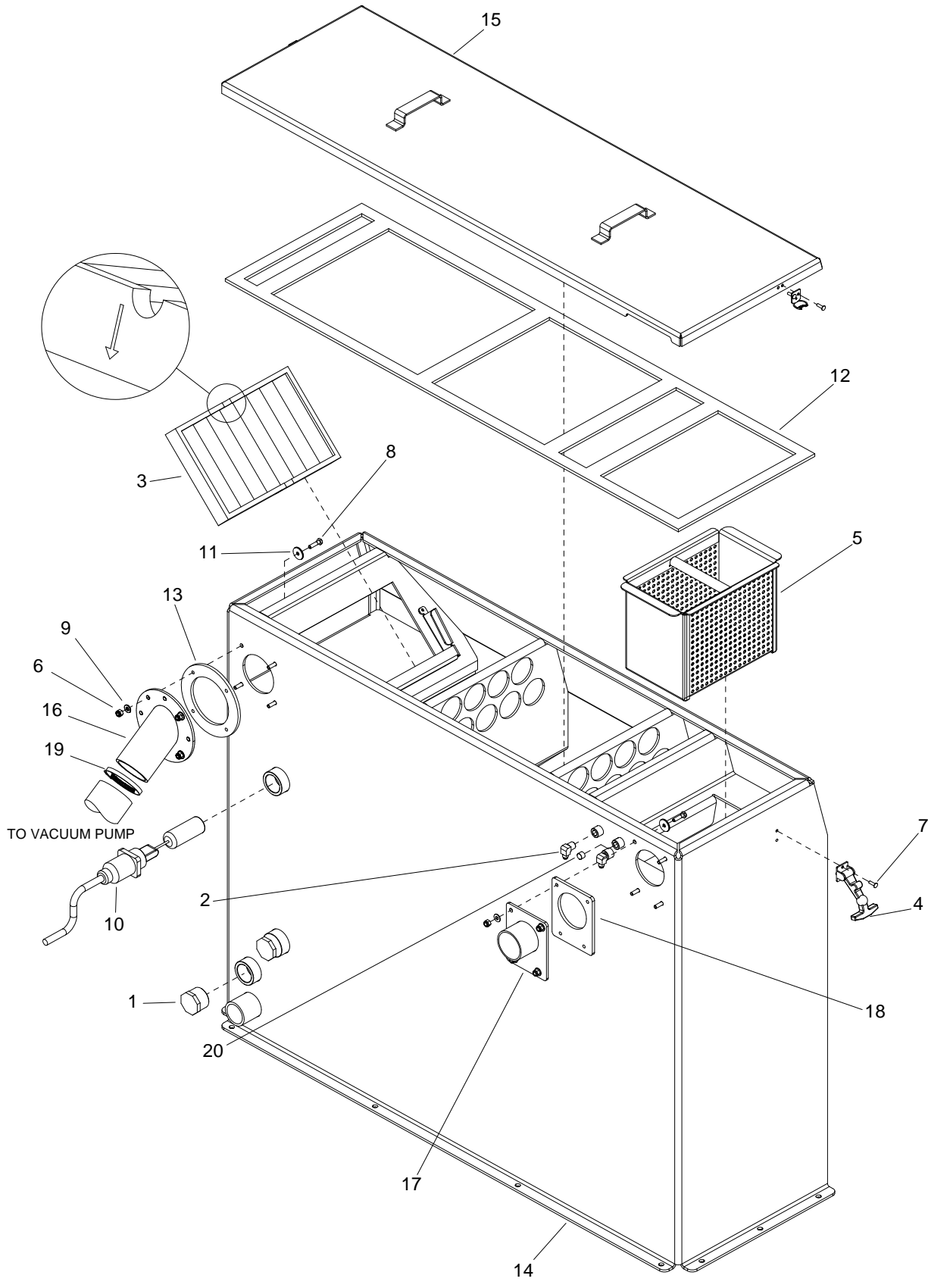

REF	PART NO.	PRV NO.	QTY	DESCRIPTION	SERIAL NO. FROM	NOTES
-	86329250	-	1	KIT, WASTE TANK 100 G, LGT/BGT PC		COMPLETE
1	86190530	11-800402	2	PLUG, 1-1/4 HXHD PVC		
2	86180340	12-800031	2	ELL, 1/4P X 1/4T BR		
3	86193540	14-806569	1	STRNR, WST TNK, RECT, 1.5		
4	86186860	46-802510	2	LATCH, DRAW 2-7/8 SST		
5	86043190	56-501793	1	STRAINER BOWL, AVENGER 450		
6	86005810	57245	8	NUT, 1/4-20 HEX NYLOCK SS		
7	86273020	67006	8	RIVET, 3/16 OD X 5/8 AL		
8	86273810	70018	8	SCR, 1/4-20 X 1 HHCS SS		
9	86010630	87013	8	WASHER, 1/4 X 5/8 FLAT SS		
10	86193870	791066	1	ASSY, LVL SENS SHTOF SW		
11	86202240	-	8	WASHER, SEAL 1/4 X 1 OD SS		
12	86325770	-	1	GASKET, 100G LID WST TNK		
13	86318560	-	1	GASKET, VAC OUTLET		
14	86325650	-	1	TANK, WASTE, 100G PC		
15	86325720	-	1	LID, 100G WST TNK, PC		
16	86321040	-	1	OUTLET, VACUUM, 2-7/8", PC		
17	86323650	-	1	INLET, 2-1/2" VACUUM, PC		
18	86323700	-	1	GASKET, VAC INLET		
19	86177010	03-000112	1	CLAMP, HOSE #48		
20	86272720	11-800345	1	PLG, 1/4 SOCHD BRASS		

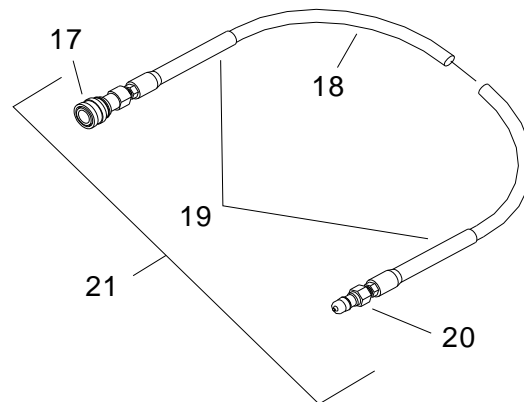
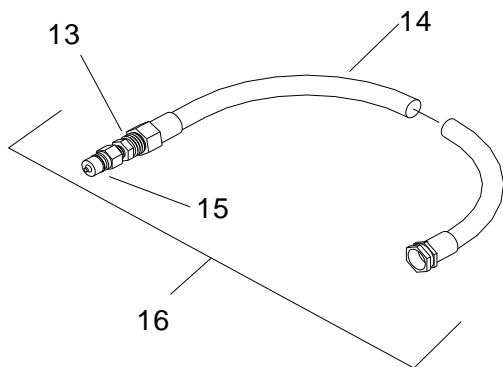
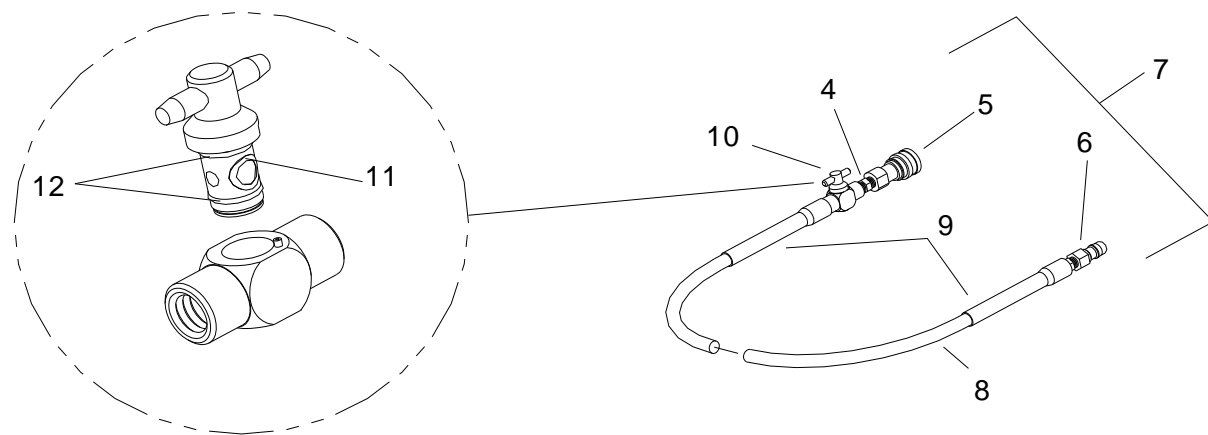
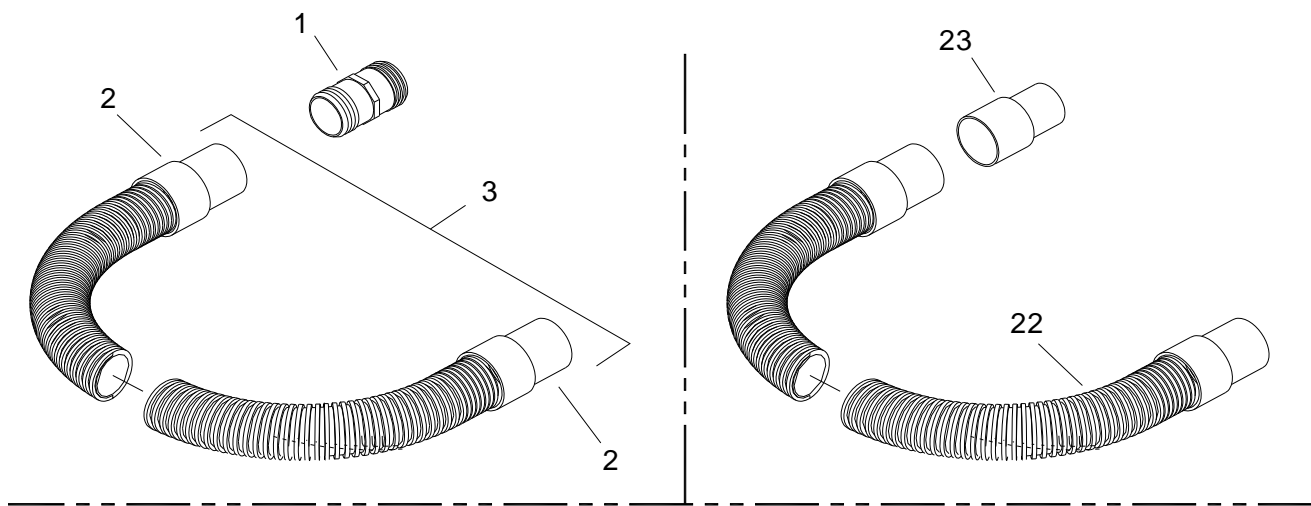

REF	PART NO.	PRV NO.	QTY	DESCRIPTION	SERIAL NO. FROM	NOTES:
1	86180980	12-800078	1	FITTING, BRB 2H BS PVC		
2	86178640	08-805147	2	CUFF, 2"		
3	86184510	10-805060	1	HOSE, VAC 2"X50' W/ CUFFS & HOSE		
4	86247680	56015	1	NIPPLE, 1/4 HEX		
5	86002450	22015	1	COUPLER, 1/4 QD		
6	86005580	56012	1	NIPPLE, 1/4 FPT QD		
7	86184530	10-805108	1	HOSE, HP 1/4 X 50FT W/QD & VLVE		
8	86184520	10-805077	1	HOSE, HP 1/4 X 50'		
9	86182800	08-805155	2	GUARD, HOSE VINYL		
10	86194990	15-808012	1	VALVE, BALL 1/4FP		
11	86189240	43-810014	2	O-RING, 7/32ID X 11/32OD		
12	86189250	43-810019	2	O-RING, 3/8 ID X 1/2 OD		
13	86188210	11-800354	1	NIP, 1/2 X 3/8 HEX BR		
14	86184570	10-805157	1	HOSE, WATER 1/2 X 50'		
15	86179630	13-806009	1	DISCONNECT 3/8M X 3/8FP		
16	86184620	10-805295	1	HOSE, WATER 1/2 X 50'		
17	86002450	22015	1	COUPLER, 1/4 QD		
18	86184520	10-805077	1	HOSE, HP 1/4 X 50'		
19	86182800	08-805155	2	GUARD, HOSE VINYL		
20	86005580	56012	1	NIPPLE, 1/4 FPT QD		
21	86184540	10-805122	1	HOSE, HP 1/4 X 50FT W/QD		
22	86328140	-	1	HOS, VAC 2-1/2" X 50' W/CUFFS & HOSE		
23	86328150	-	1	COUPLER, HOS 2-1/2" TO 2" REDUCER		

# Battery Floor Mount

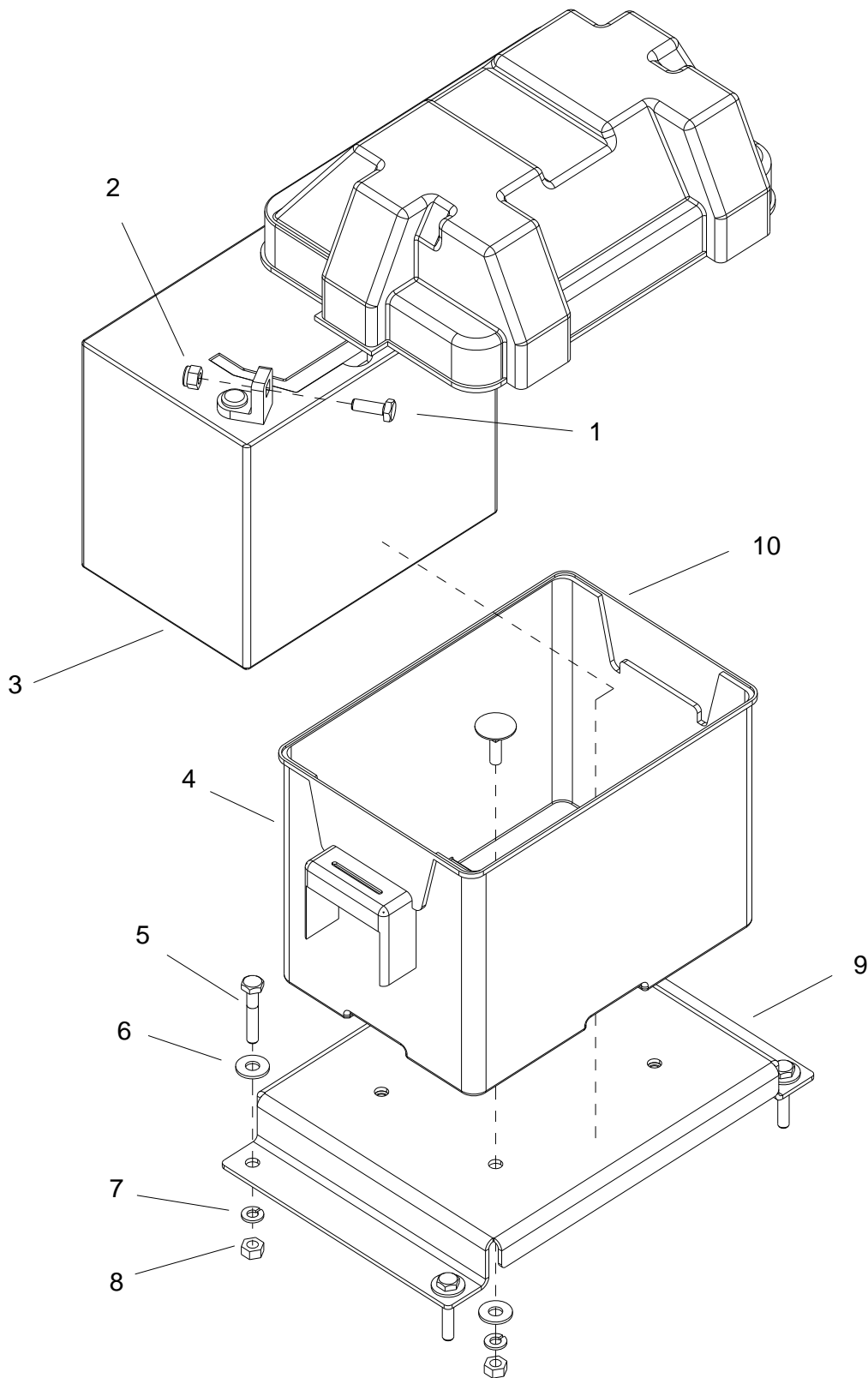



REF	PART NO.	PRV NO.	QTY	DESCRIPTION	SERIAL NO. FROM	NOTES:
1	86273780	70015	2	SCR, 1/4-20 X 3/4 HHCS SS NP		
2	86005680	57047	2	NUT, 1/4-20 HEX NYLOCK		
3	86174580	36-900056	1	BATTERY		
4	86012060	-	1	BOX, BATTERY, MODIFIED		
5	86273190	00-000132	4	SCR, 1/4-20 X 1-1/2 HXHD		
6	86270330	02-000066	8	FLATWASHER, 1/4		
7	86010780	87162	8	WASHER, 1/4 SPLIT LOCK PLTD		
8	86270770	57006	8	NUT, 1/4-20 HEX		
9	86309890	-	1	BRKT, BATTERY BOX MTG		
10	86011470	-	4	BOLT, ELEVATOR, 1/4-20 X 1		

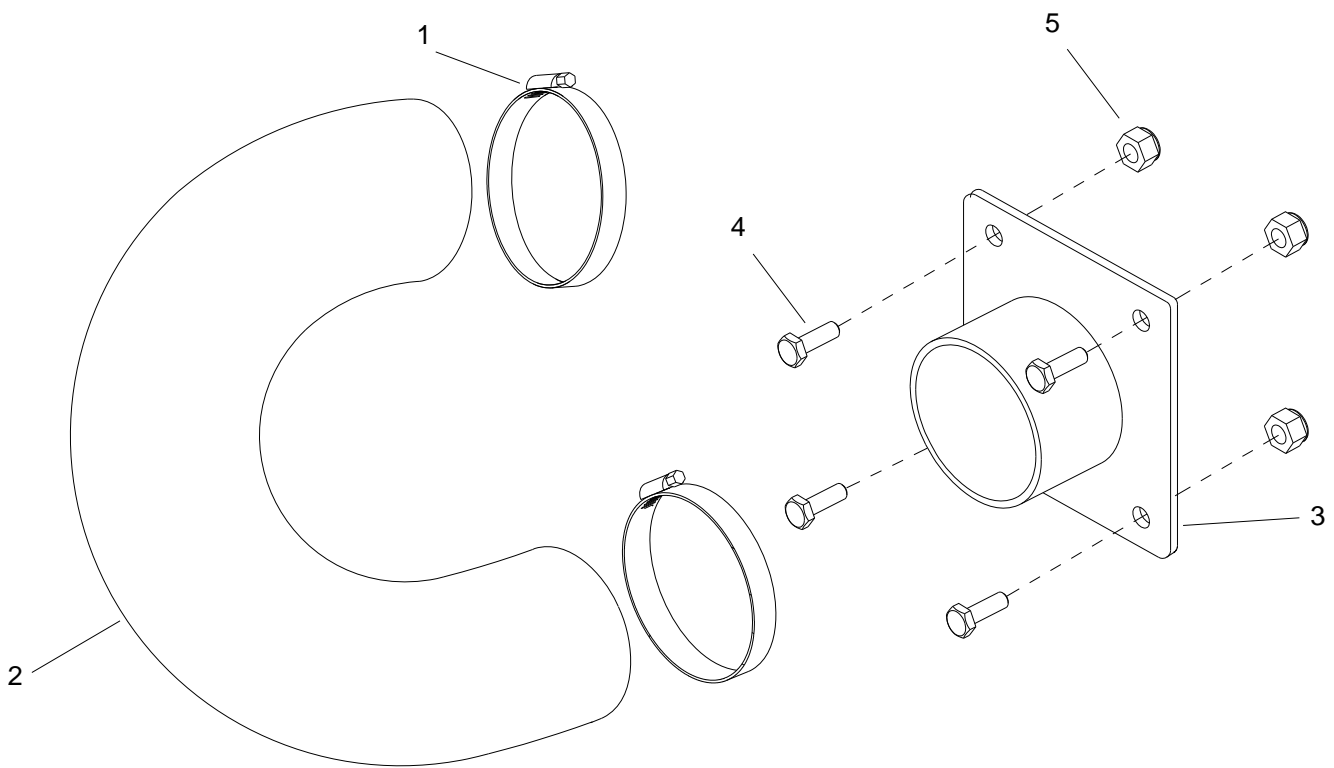

REF	PART NO.	PRV NO.	QTY	DESCRIPTION	SERIAL NO. FROM	NOTES
1	86177010	03-000112	2	CLAMP, #48 HOSE		
2	86280600	09-805487	1	HOSE, 3" X 17" FLEXABLE		
3	86181110	56-502131	1	FLANGE, VAC EXH DUCT KIT LG		
4	86192060	00-000376	4	SCREW, 1/4-20 X 1-1/4" SST		
5	86005810	57245	4	NUT, 1/4-20 HEX NYLOCK SS		
-	86030440	47447	1	KIT, EXHAUST 3"ID, SINGLE		KIT COMPLETE

Automatic Pumpout - Optional

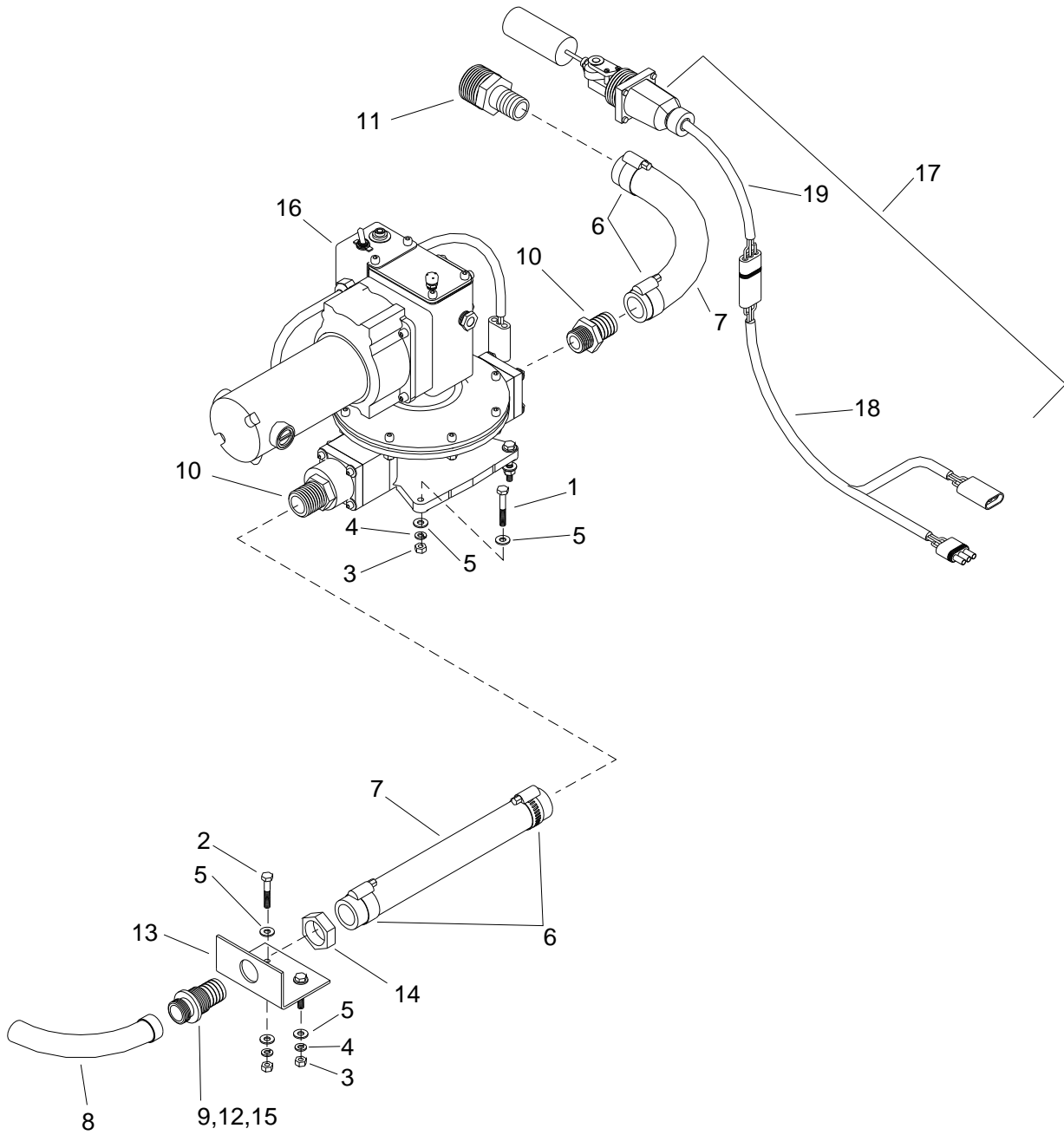

REF	PART NO.	PRV NO.	QTY	DESCRIPTION	SERIAL NO. FROM	NOTES:
1	86274150	70105	4	SCR, M4 X 60 PH		
2	86273190	00-000132	2	SCR, 1/4-20 X 1/ 1/2 HXHD		
3	86270770	57006	4	NUT, 1/4-20 HEX		
4	86010780	87162	4	WASHER, 1/4 SPLIT LOCK PLTD		
5	86270330	02-000066	4	FLATWASHER, 1/4		
6	86177050	03-000176	4	CLAMP, HOSE #16		
7	86280680	09-805591	1	HOSE, WASTE PUMP 1" X 8'		
8	86184780	10-805484	1	HOSE, GARDEN 3/4 X 75'		
9	86176420	12-800052	1	CAP, HOSE 3/4 BR		
10	86181430	12-800367	1	FTTG, BRB 1PX1H BR		
11	86181440	12-800444	1	FTTG, 1-1/4P X 1" H BR		
12	86195820	43-807008	1	WASHER, HOSE 5/8 ID 1" OD		
13	86175720	50-502055	1	BRKT, CTR HOOD FR		
14	86188970	52-000123	1	NUT, 1-3/16-12 UN HXHD		
15	86162270	52-501993	1	CONN, HOSE WATER OUTL		
16	86191380	61-951306	1	PUMP, HD AUTO		
17	86174260	61-951319	1	ASSY, LVL SENS SHUT OFF SW		
18	86195860	23719	1	CORD ASM, CNCTN SIDE		
19	86195910	72185	1	SWITCH ASSEMBLY		

# Automatic Pumpout - Optional

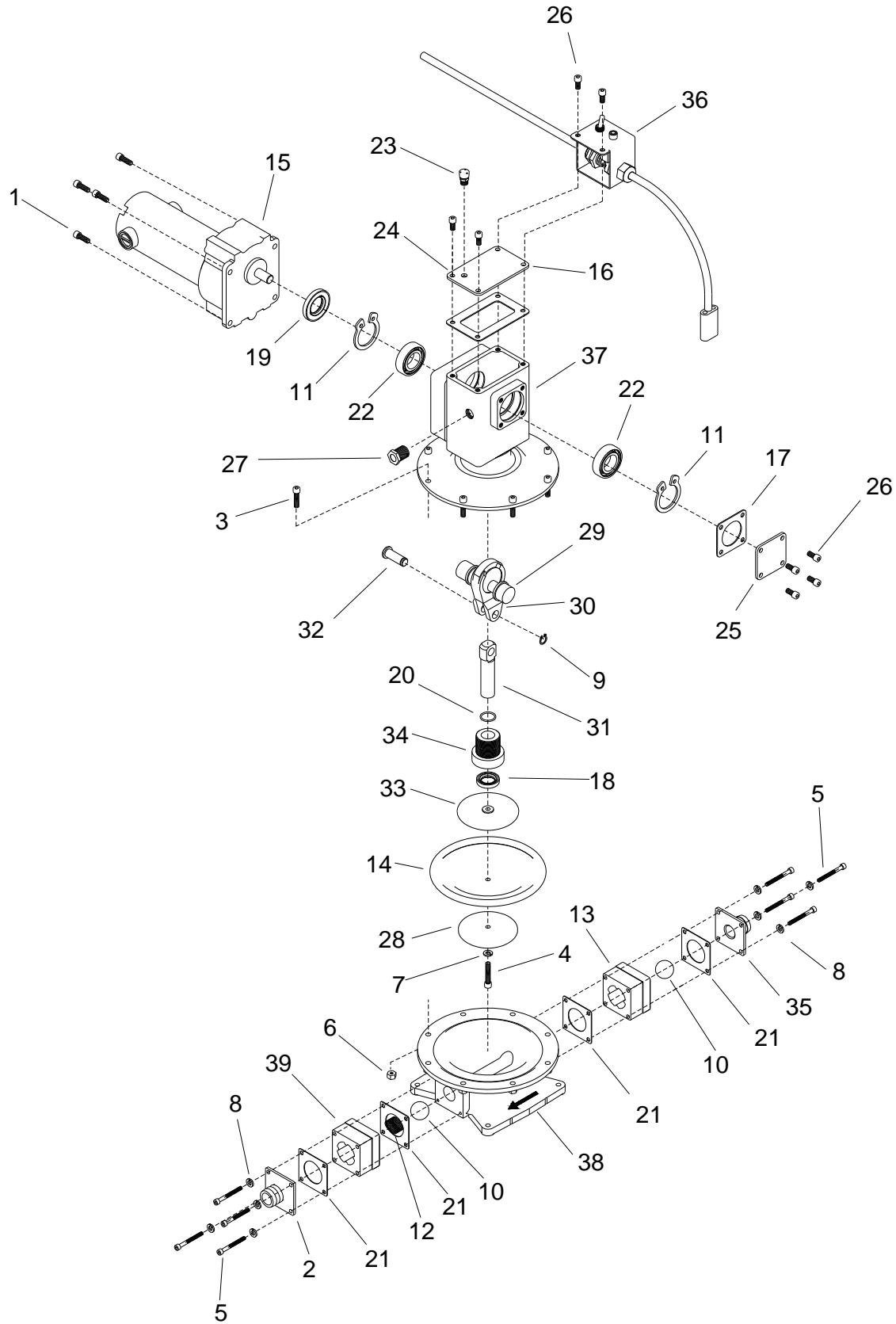

REF	PART NO.	PRV NO.	QTY	DESCRIPTION	SERIAL NO. FROM	NOTES:
1	86273250	00-000210	4	SCR, 1/4-20 X 3/4 SOCHD		
2	86178820	52-502064	1	CVR, OUTLET WST PMP-OUT		
3	86192020	00-000312	8	SCR, CAP 1/4 X 1 SOCHD		
4	86273550	00-000399	1	SCR, CAP 1/4 X 1 3/8 SOC		
5	86273280	00-000241	8	SCR, CAP 10-32 X 2 SOCHD SS		
6	86005810	57245	8	NUT, 1/4-20 HEX NYLOCK SS		
7	86010780	87162	1	WASHER, 1/4 SPLIT LOCK		
8	86279470	87165	8	WASHER, #10 SPLIT LOCK		
9	86024840	04-000312	1	RING, RETAIN EXT 1/2		
10	86174520	04-000334	2	BALL, NYL ID		
11	86024850	04-000335	2	RING, SNAP 1-7/8D		
12	86193250	04-000342	1	SPRING, PUMP-OUT BALL PRESS		
13	86174700	52-502061	1	BDY, INLET WST PMP-OUT		
14	86179530	16-808241	1	DIAPH, WST TNK PMP-OUT		
15	86187870	40-902151	1	MOTOR, 1/8HP 12V		
16	86182540	43-807117	1	GSKT, CVR TOP PMPOUT		
17	86182550	43-807118	1	GSKT, CVR SD PMPOUT		
18	86192300	43-810091	1	SEAL, PUMPOUT SHFT		
19	86192350	43-810100	1	SEAL PUMPOUT CAM		
20	86189600	43-810101	1	O-RING, 800/1000 .072		
21	86189280	43-810106	4	O-RING, 1-13/16 ID X 2 OD HDWP		
22	86175530	45-801927	4	BRG, SHFT PUMP-OUT		
23	86195190	49-876301	1	VENT, UPR SHFT BRNG HSG		
24	86050890	50-502025	1	PL, CVR TOP PUMP-OUT		
25	86024860	50-502026	1	PL, CVR SD PUMP-OUT		
26	86274110	70094	8	SCR, 1/4-20 X 1/2 SHCS SS		
27	86181680	11-800504	1	GA, FLOW SIGHT 3/8 NPT		
28	86175830	52-501828	1	BTM, PLNGR WST TNK PMP-OUT		
29	86192690	52-501829	1	SHT, 3/4" STROKE WST TNK		
30	86191550	52-501914	1	RD, CONNECT WST PMP-OUT		PART OF 31
31	86182810	52-501915	1	GUIDE, PLNGR WST PUMP-OUT		INCL. 32, 18, 30
32	86024870	52-501921	1	PIN, WRIST PUMP-OUT		
33	86194640	52-501934	1	TOP, PLNGR PUMP-OUT		
34	86176020	52-501950	1	BUSH, THREADED		
35	86178810	52-502062	1	CVR, INLET WST PMP-OUT		
36	86045790	56-502428	1	BRKT, PMP-OUT SW/CCT BRKR		
37	86024880	52-501821	1	TOP, WST TNK PUMP-OUT		
38	86174550	52-501820	1	BASE, WST TANK PMP-OUT		
39	86174710	52-502063	1	BDY, INLET WST PMP-OUT		

Wand - Titanium Six Jet - Optional

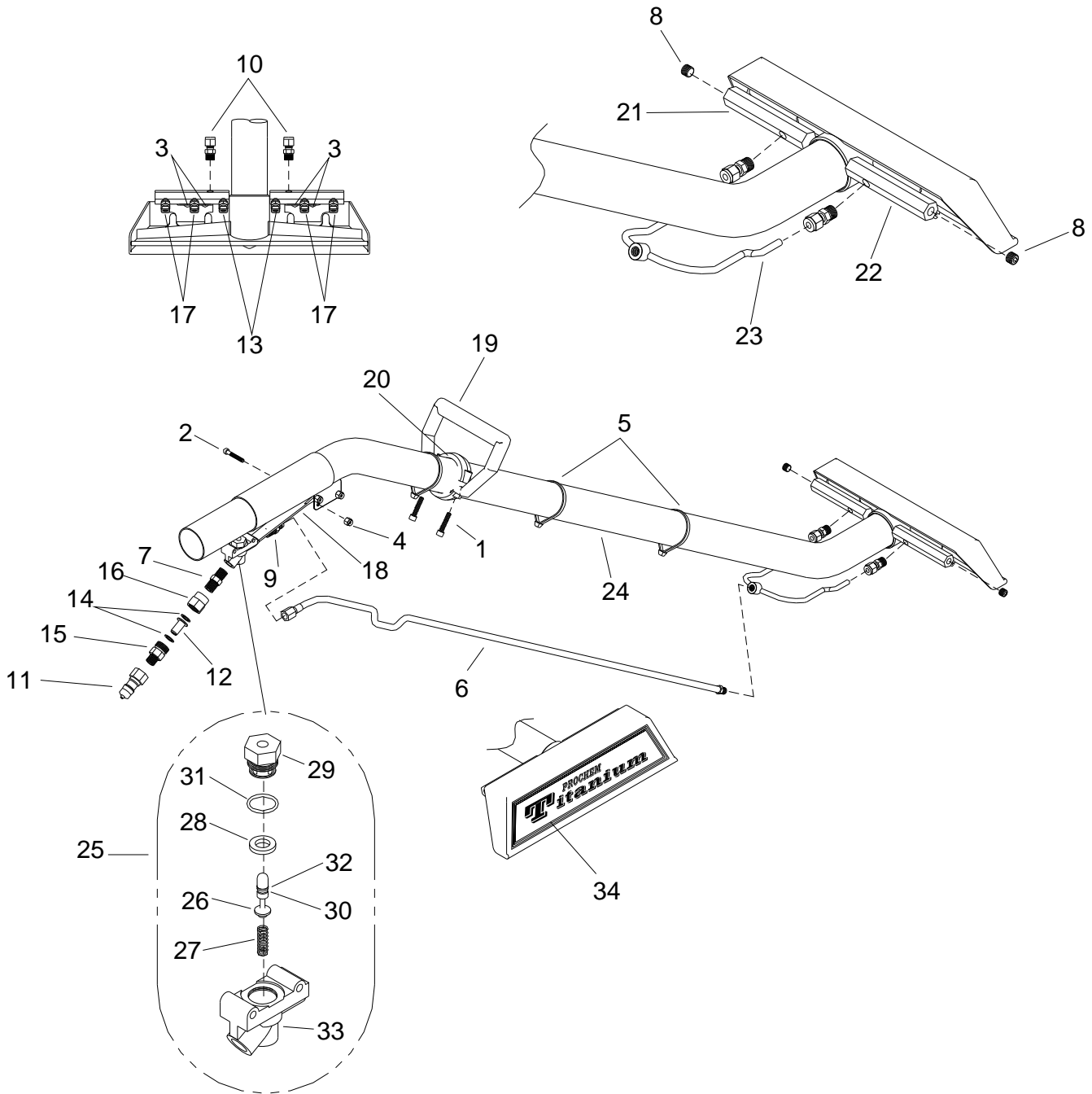



REF	PART NO.	PRV NO.	QTY	DESCRIPTION	SERIAL NO. FROM	NOTES:
1	86273310	00-000282	2	SCR, CAP 1/4-20 X 1 1/4 SOC		
2	86192030	00-000317	2	SCR, CAP 10-32 X 1 1/4 SOCH		
3	86006680	70228	4	SCR, 10-32 X 1/4 PPHMS SS		
4	86270990	57090	2	NUT, 10-32 HEX NYLOCK SS		
5	86264910	04-000093	2	TIE, CABLE 13"		
6	86184270	10-805504	1	HOSE, 3/16 X 44-1/2		
7	86247680	56015	1	NIPPLE, 1/4 HEX		
8	86190180	11-800206	2	PLUG, 1/8 SOCHD BR		
9	86177650	12-800060	1	CONN, 1/4P X 1/4T BR		
10	86177710	12-800322	2	CONN, 1/8P X 1/4T COMP BR		
11	86005580	56012	1	NIPPLE, 1/4 FPT QD		
12	86193490	14-806512	1	STRAINER, JET 50 MESH		
13	86194450	17-803018	2	TIP, SPRAY 9501 X 1/8P SST		
14	86195570	17-803006	2	WASHER, NYLON		
15	86177860	17-803010	1	CONN, 1/4P X 11/16-16M		
16	86177870	17-803036	1	CONN, 1/4FP X 11/16-16F BR		
17	86194580	17-803078	4	TIP, SPRAY 8001 SST \1/8 VJET		
18	86194650	52-501619	1	TRIGGER, WD VALVE		
19	86174680	52-502008BK	1	BODY, WD HDL, 2" TB, BK		
20	86198180	52-502009	1	HOLD DN-WD HDL 2" TUBE		
21	86187610	52-502057	1	MANFOLD, LEFT		
22	86187620	52-502058	1	MANIFOLD, RIGHT		
23	86174060	56-502548	1	ASSY, MNFLD S-BEND		
24	86285440	56-502534	1	WD & HD, TITANIUM		
25	86174120	61-950496	1	ASSY, EXTRACTOR VALVE		
26	86193360	16-808189	1	STEM, EXTRACTOR VALVE		
27	86193200	16-808190	1	SPRING, EXTRACTOR VALVE		
28	86192410	16-808228	1	SEAT, EXTRACTOR VALVE		
29	86183160	16-808229	1	HLDR, VLV STEM-EXTRACTOR VL		
30	86189510	43-810062	1	O-RING, .114 ID .254OD		
31	86189520	43-810063	1	O-RING, .551ID .691OD		
32	86174500	43-810064	1	BACK-UP, .250DIA		
33	86174630	52-501590	1	BDY, EXTRACTOR VLV		
34	86179250	48-941462	1	DEC, WD HD TITANIUM		

Wand - Ergo Titanium Six Jet - Optional

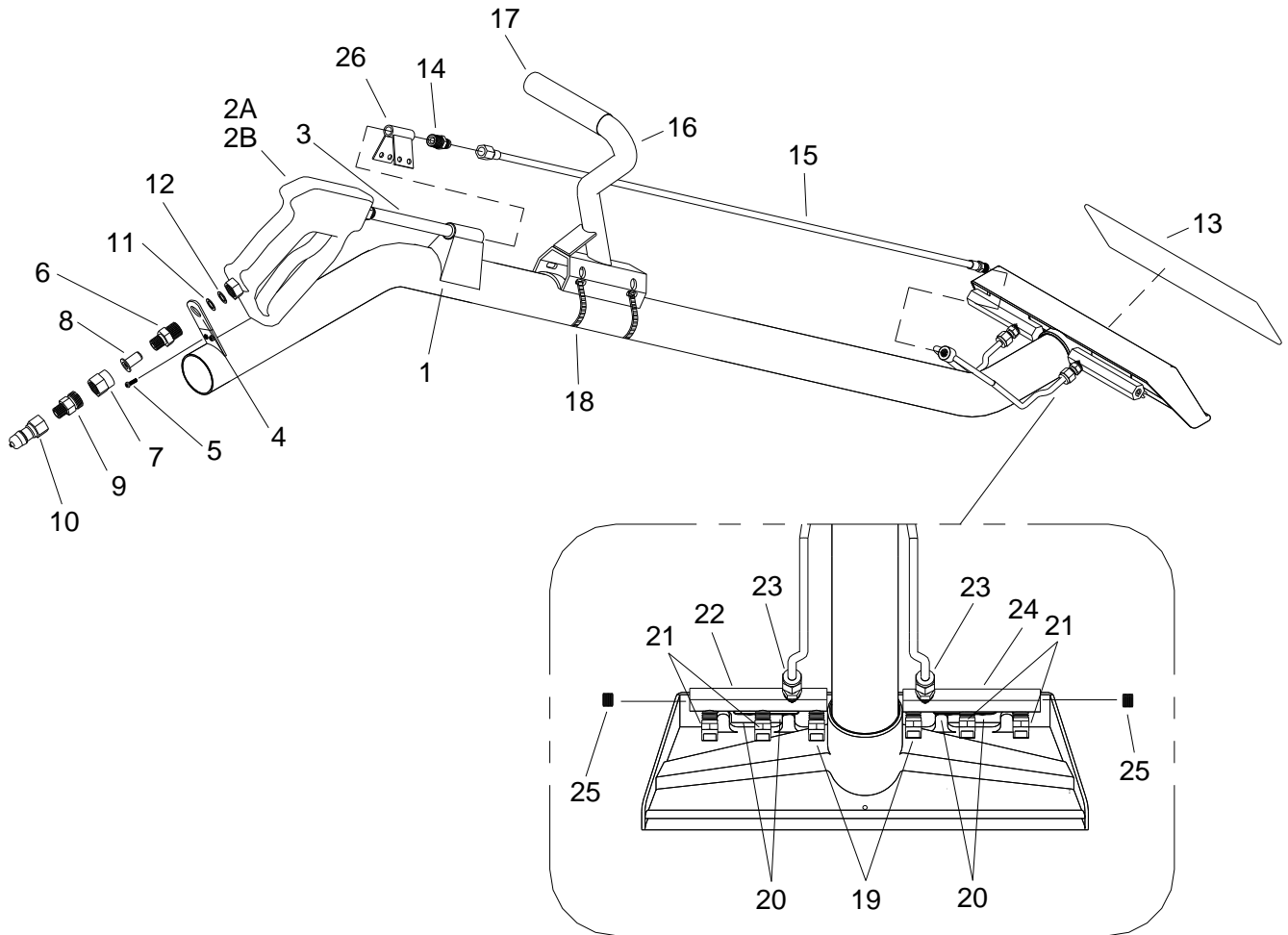

REF	PART NO.	PRV NO.	QTY	DESCRIPTION	SERIAL NO. FROM	NOTES
-	86326900	-	1	WAND, ERGO TI		COMPLETE
1	86195560	791121	1	WAND/HEAD WELDMENT		
2A	86182820	17-803025	1	GUN, PRESS WASH TM		
2B	86011740	-	1	YG5000 SPRAY GUN ASM		
3	86188590	791122	1	NIPPLE, 1/4 X 5 SS		
4	86175760	791123	1	BRKT, HNDL, CLMP		
5	86277760	791124	2	SCR, 8-32 X 1/4 SHCS SS		
6	86188280	11-800381	1	NIP, 3/8 X 1/4 HX SST		
7	86177870	17-803036	1	CONN, 1/4FP X 11/16-16F BR		
8	86193490	14-806512	1	STRNR, JET 50 MESH		
9	86177860	17-803010	1	CONN, 1/4 X 11/16-16M		
10	86005580	56012	1	NIP, 1/4 FPT QD		
11	86195600	791127	1	WASHER, BLK WD		
12	86195610	791128	1	WASHER, FLAT SS WD		
13	86179020	48-941186	1	DEC, WD HD (CAST SST) TM		
14	86177650	12-800060	1	CONN, 1/4P X 1/4T BR		
15	86031580	10-805245	1	HOSE, 3/16 X 40-1/2		
16	86183110	46-802553	1	HDL, TITANIUM WND W/SPYR		
17	86182120	791125	1	GRIP, BLU HANDLE		
18	86177150	791126	2	CLAMP, #38 HOSE SS		
19	86194450	17-803018	2	TIP, SPRY 9501 X 1/8P SST		
20	86270990	57090	4	NUT, 10-32 HEX SS NYLOCK		
21	86194580	17-803078	4	TIP, SPRAY 8001 SST 1/8 VJE		
22	86187620	52-502058	1	MNFLD, LT TITAN		
23	86177710	12-800322	2	CONN, 1/8P X 1/4T COMP BR		
24	86187610	52-502057	1	MNFLD, RT TITAN		
25	86190180	11-800206	2	PLG, 1/8 SOCHD BR		
26	86175660	140160	1	BRKT, MANIFOLD, WAND		
-	86186100	47453	1	KIT, REPAIR 17-803025		NOT SHOWN

Wand - Quad Jet - Optional

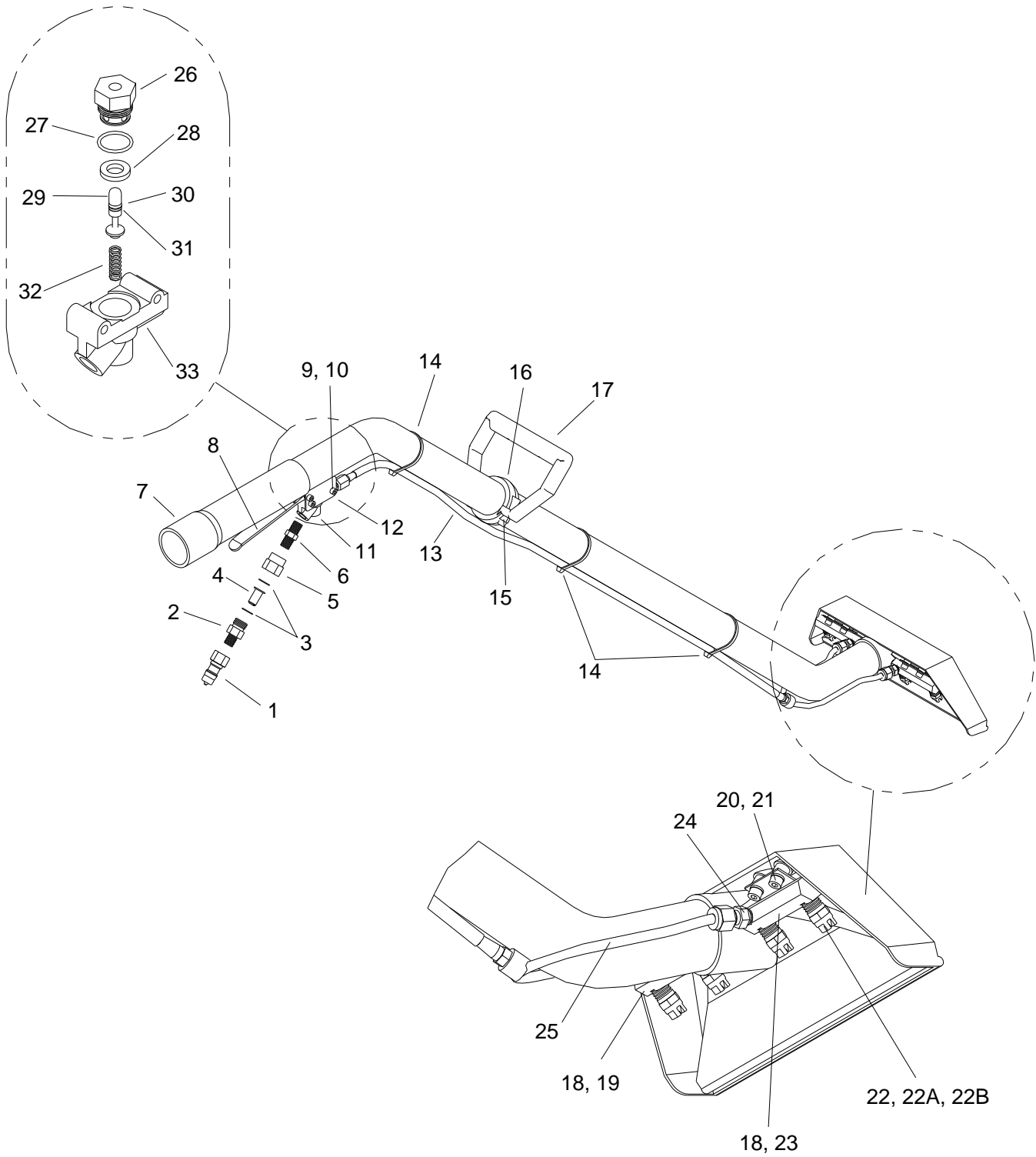

REF	PART NO.	PRV NO.	QTY	DESCRIPTION	SERIAL NO. FROM	NOTES:
1	86005580	56012	-	NIPPLE, 1/4 FPT QD		
2	86177860	17-803010	1	CONN, 1/4P X 11/16-16M		
3	86195570	17-803006	1	WASHER, NYLON		
4	86193490	14-806512	2	STRAINER, JET 50 MESH		
5	86177870	17-803036	1	CONN, 1/4FP,11/16-16R BR		
6	86247680	56015	1	NIPPLE, 1/4 HEX		
7	86280020	09-805359	1	SLEEVE, WD HDL 9.5		
8	86194650	52-501619	1	TRIGGER, WD VLV		
9	86192030	00-000317	3	SCR, CAP 10-32X 1-1/4 SOCH		
10	86270990	57090	3	NUT, 10-32 HEX NYLOCK SS		
11	86174120	61-950496	1	ASSY, EXTRCTR VLV		
12	86177650	12-800060	1	CONN, 1/4P X 1/4T BR		
13	86183970	10-805387	1	HOSE, 3/16 X 43-1/2 (1/8P X 1/4)		
14	86265730	04-000053	3	TIE, CABLE 8" WHT		
15	86273310	00-000282	2	SCR, CAP 1/4-20 X 1-1/4 SOC		
16	86198160	52-501569	1	HOLD DOWN, WD HDL		
17	86182840	791150	1	BODY, WD HDL		
18	86190180	11-800206	2	PLUG, 1/8 SOCHD BR		
19	86043300	56-501966	1	ASSY, L S-BEND MNFLD		
20	86273450	00-000347	4	SCR, CAP 10-24 X1/4 SOCHD		
21	86279470	87165	4	WASHER, #10 SPLIT LOCK		
22	86194400	17-803001	4	TIP, SPRY 95015X1/8P SST		89238
22A	86194410	17-803002	4	TIP, SPRY 9502X1/8P SST		89239
22B	86194450	17-803018	4	TIP, SPRY 9501X1/8P SST		89237 89235 (NO DECAL)
23	86043310	56-501986	1	ASSY, RT S-BEND MNFLD		
24	86177710	12-800322	2	CONN, 1/8PX1/4T COMP BR		
25	86174030	56-501967	1	ASSY, S-BEND MNFLD		
26	86183160	16-808229	1	HOLDER, VLV STEM-EXTRCTR VL		
27	86189520	43-810063	1	O-RING, .551 ID .691 OD		
28	86192410	16-808228	1	SEAT, EXTRCTR VLV		
29	86193360	16-808189	1	STEM, EXTRCTR VLV		
30	86174500	43-810064	1	BACK-UP, .250 DIA		
31	86189510	43-810062	1	O-RING, .144 ID .254 OD		
32	86193200	16-808190	1	SPRING, EXTRCTR VLV		
33	86174630	52-501590	1	BODY, EXTRCTR VLV		
-	86179020	48-941186	1	DECAL, WD HD (CAST SS)		
-	86186160	66-808169	-	KIT, REP-WD VLV		INCLUDES PARTS 27-29 & 31-33
-	86285570	89238	-	WAND, TM, QJW (95015) PC		COMPLETE
-	86285580	89239	-	WAND, TM, QJW (9502) PC		COMPLETE
-	86285560	89237	-	WAND, TM QJW (9501) PC		COMPLETE
-	86285540	89235	-	WAND, TM, QJW, (9501) NO DECAL		COMPLETE

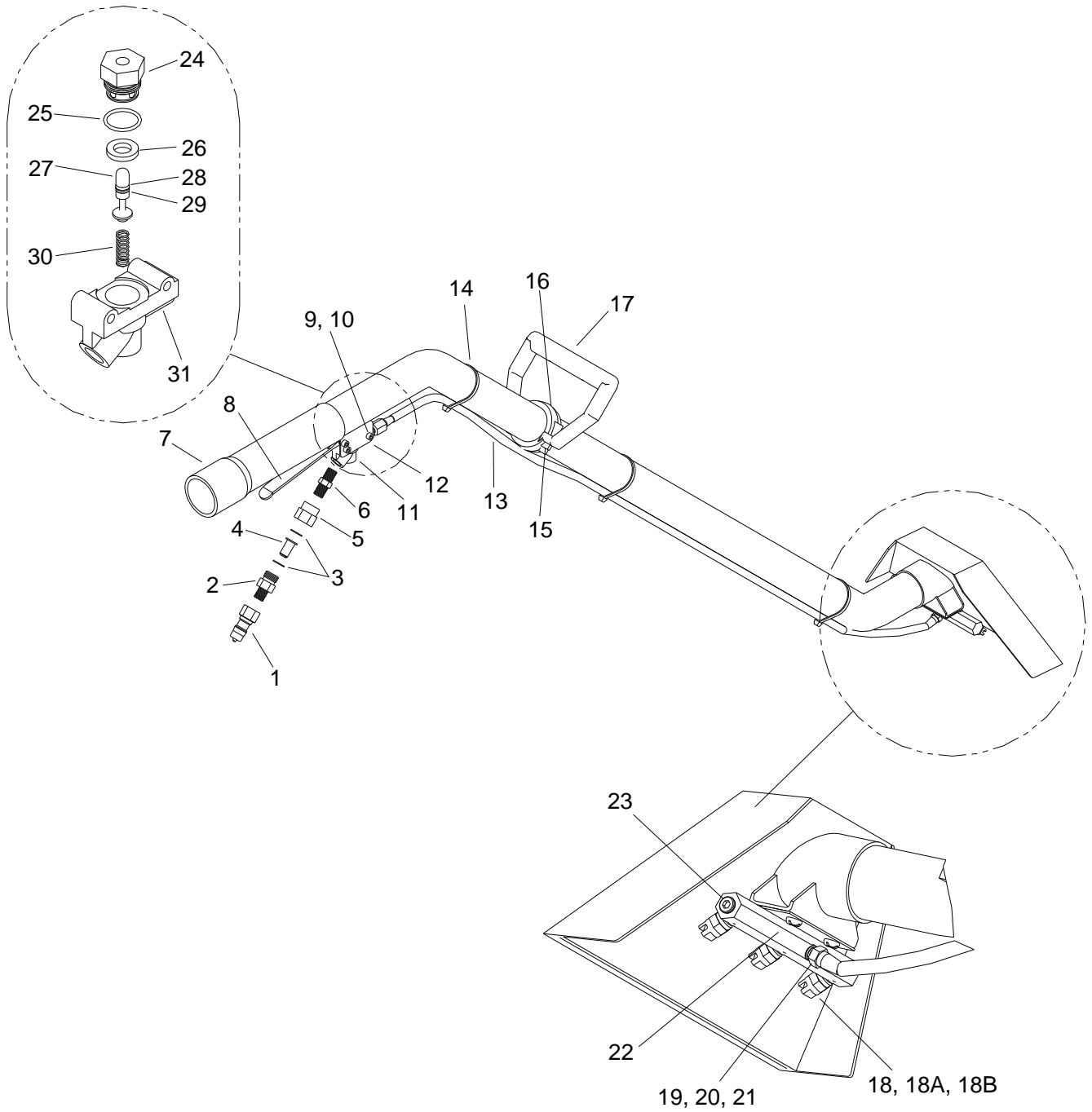

REF	PART NO.	PRV NO.	QTY	DESCRIPTION	SERIAL NO. FROM	NOTES:
1	86005580	56012	1	NIPPLE, 1/4 FPT QD		
2	86177860	17-803010	1	CONN, 1/4P X 11/16-16M		
3	86195570	17-803006	2	WASHER, NYLON		
4	86193490	14-806512	1	STRAINER, JET 50MESH		
5	86177870	17-803036	1	CONN, 1/4FP, 11/16-16R BR		
6	86247680	56015	1	NIPPLE, 1/4 HEX		
7	86280020	09-805359	1	SLEEVE, WD HDL 9.5		
8	86194650	52-501619	1	TRIGGER, WD VLV		
9	86192030	00-000317	3	SCR, CAP 10-32X 1-1/4 SOCH		
10	86270990	57090	3	NUT, 10-32 HEX NYLOCK SS		
11	86174120	61-950496	1	ASSY, EXTRCTR VLV		
12	86177650	12-800060	1	CONN, 1/4P X 1/4T BR		
13	86183970	10-805253	1	HOSE, 3/16X49 (1/8P X 1/4FT)		
14	86265730	04-000053	3	TIE, CABLE 8" WHT		
15	86273310	00-000282	1	SCR, CAP 1/4-20 X 1-1/4 SOC		
16	86198160	52-501569	1	HOLD DOWN, WD HDL		
17	86182840	791150	1	BODY, WD HDL		
18	86194410	17-803002	3	TIP, SPRY 9502X1/8P SST		89233
18A	86194400	17-803001	3	TIP, SPRY 9501X1/8P SST		89232
18B	86194520	17-803046	3	TIP, SPRY 9503X1/8P SST		89234
19	86274290	70162	2	SCR, 10-32 X 3/8 PPHMS SS		
20	86279470	87165	2	WASHER, #10 SPLIT LOCK		
21	86270800	57014	2	NUT, 10-32 HEX SS		
22	86187700	56-501739	1	MANIFOLD, WD TRI-JET		
23	86190180	11-800206	2	PLUG, 1/8 SOCHD BR		
24	86183160	16-808229	1	HOLDER, VLV STEM-EXTRCTR VL		
25	86189520	43-810063	1	O-RING, .551 ID .691 OD		
26	86192410	16-808228	1	SEAT, EXTRCTR VLV		
27	86193360	16-808189	1	STEM, EXTRCTR VLV		
28	86174500	43-810064	1	BACK-UP, .250DIA		
29	86189510	43-810062	1	O-RING, .114ID .254OD		
30	86193200	16-808190	1	SPRING, EXTRCTR VLV		
31	86179020	52-501590	1	BODY, EXTRCTR VLV		
-	86179020	48-941166	-	DECAL, WD HD		
-	86186160	66-808169	-	KIT, REP-WD VLV		INCLUDES PARTS 25-27 & 29-31
-	86285520	89233	-	WAND, TJW (9502) PC		COMPLETE
-	86285510	89232	-	WAND, TJW, (95015) CUBXL		COMPLETE
-	86285530	89234	-	WAND, TJW, (9503) PC		COMPLETE

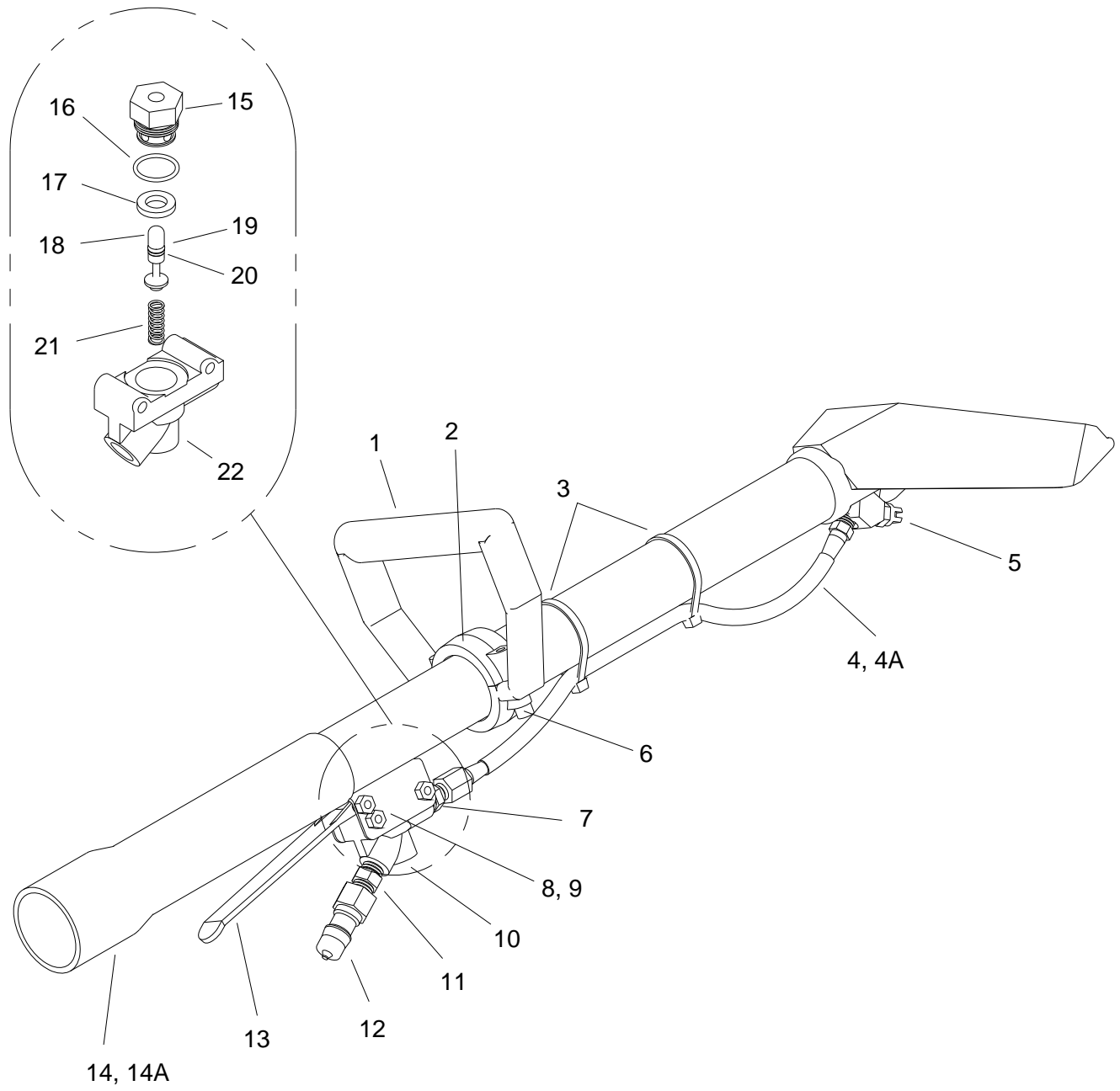



REF	PART NO.	PRV NO.	QTY	DESCRIPTION	SERIAL NO. FROM	NOTES:
1	86198080	52-501576	1	BODY, WD HDL PORT		
2	86198170	52-501577	1	HOLD DOWN, WD HDL PORT		
3	86265730	04-000053	2	TIE, CABLE 8" WHT		
4	86183710	10-805330	1	HOSE, 3/16X13-3/4 (1/8PX1/4)		
4A	86184000	10-805397	1	HOSE, 3/16X7-1/2 (1/8P X 1/4F)		
5	86194410	17-803002	1	TIP, SPRY 9502X1/8P SST		
6	86273310	00-000282	2	SCR, CAP 1/4-20 X 1-1/4 SOC		
7	86177650	12-800060	1	CONN, 1/4P X 1/4T BR		
8	86192030	00-000317	3	SCR, CAP 10-32X1-1/4 SOCH		
9	86270990	57090	3	NUT, 10-32 HEX NYLOCK SS		
10	86174120	61-950496	1	ASSY, EXTRCTR VLV		
11	86247680	56015	1	NIPPLE, 1/4 HEX		
12	86005580	56012	1	NIPPLE, 1/4 FPT QD		
13	86194650	52-501619	1	TRIGGER, WD VLV		
14	86280020	09-805359	1	SLEEVE, WD HDL 9.5		
14A	86040950	09-805504	1	SLEEVE, STAIR TL HDL 7-1/8		
15	86183160	16-808229	1	HOLDER, VLV STEM-EXTRCTR VL		
16	86189520	43-810063	1	O-RING, .551 ID .691 OD		
17	86192410	16-808228	1	SEAT, EXTRCTR VLV		
18	86193360	16-808189	1	STEM, EXTRCTR VLV		
19	86174500	43-810064	1	BACK-UP, .250DIA		
20	86189510	43-810062	1	O-RING, .114 ID .254 OD		
21	86193200	16-808190	1	SPRING, EXTRCTR VLV		
22	86174630	52-501590		BODY, EXTRCTR VLV		
-	86178970	48-941163		DECAL, STAIR TL		
-	86186160	66-808169		KIT, REP-WD VLV		INCLUDES PARTS 16-19 & 20-22
-	86285350	78519	-	TL, STAIR, LNG, TM DJ (80015)		COMPLETE
-	86285290	78521	-	TL, STAIR, SHT, TM (80015)		COMPLETE

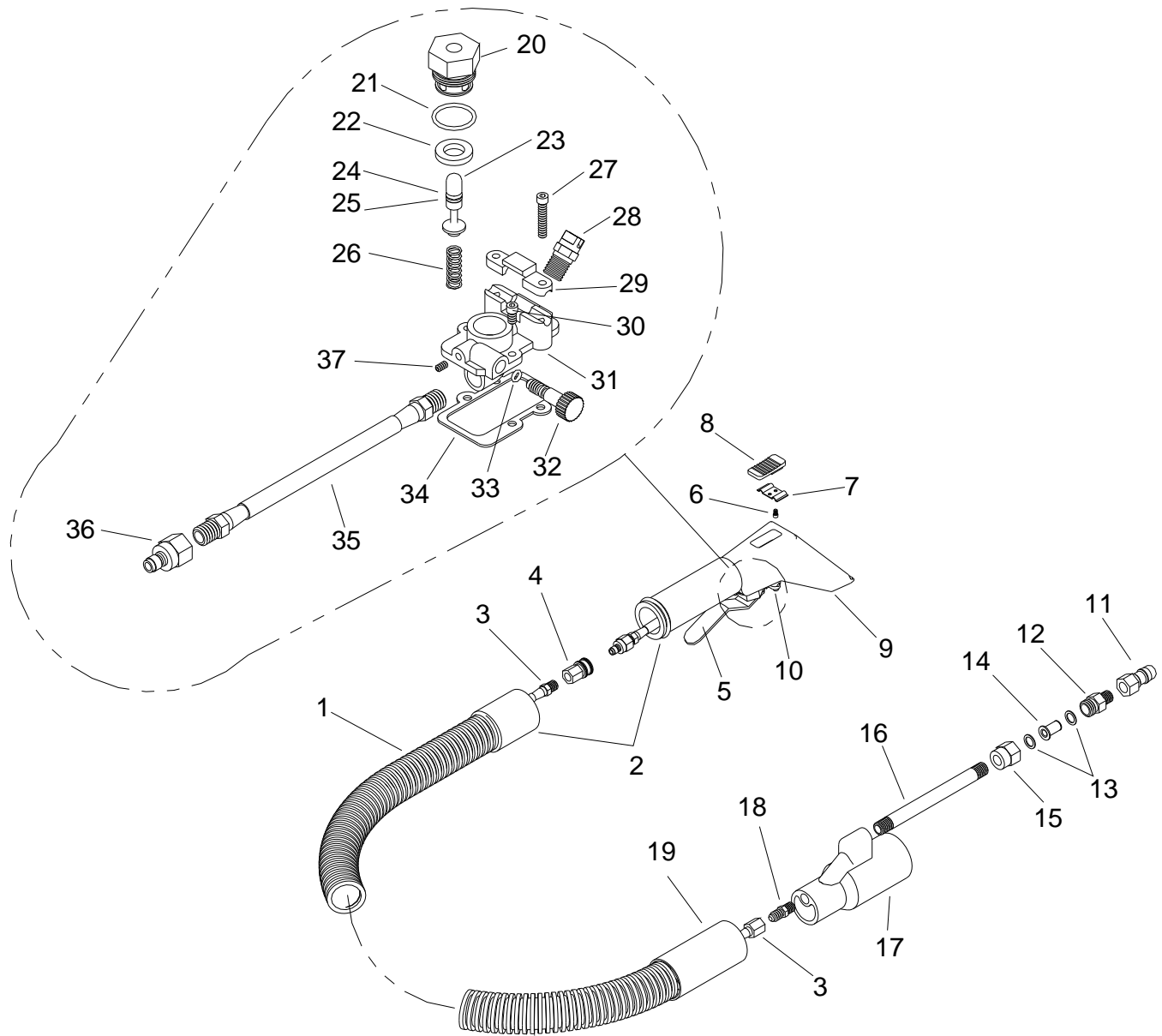

REF	PART NO.	PRV NO.	QTY	DESCRIPTION	SERIAL NO. FROM	NOTES:
-	86285260	78513	1	TL, UPHOLST, PC (80015)		COMPLETE
1	86280240	09-805131	2	HOSE, VAC 1-1/4X10' BLU		
2	86178660	08-805243	1	CUFF, SWIV 1-1/4HX1-1/4T		
3	86184670	10-805347	1	HOSE, 3/16X119-1/2 (1/8PX1/4FT)		
4	86179720	13-806023	1	DSC, 1/8FC1/8FP SST		
5	86178550	58-500639	1	UPHOLSTERY TL TRIGGER		
6	86273370	00-000310	1	SCR, CAP 4-40 X7/32 SHCS SS		
7	86193050	04-000282	1	SPRING, VAC ADJ BUTT		
8	86176080	52-501624	1	BUTTON, VAC ADJ		
9	86194590	52-501842	1	TOOL, UPHOLSTERY		
10	86174140	61-950570	1	ASSY, UPHLST TL VLV		INCLUDES PARTS 20-26, 28, & 31- 37
11	86005580	56012	1	NIPPLE, 1/4 NPT QD		
12	86177860	17-803010	1	CONN, 1/4P X 11/16-16M		
13	86195570	17-803006	1	WASHER, NYLON		
14	86193490	14-806512	1	STRAIRNER, JET 50MESH		
15	86177870	17-803036	1	CONN, 1/4FPX11/16-16F BR		
16	86188320	11-800404	1	NIP, 1/4X5 SST		
17	86178520	52-501585	1	COUPLER, UPHLST TL		
18	86177660	12-800065	1	CONN, 1/8P X 1/4T		
19	86178630	08-805138	1	CUFF, 1 1/4H X 1 1/2T GRY		
20	86183160	16-808229	1	HOLDER, VLV STEM-EXTRCTR VL		
21	86189520	43-810063	1	O-RING, .551 ID .691 OD		
22	86192410	16-808228	1	SEAT, EXTRCTR VLV		
23	86193360	16-808189	1	STEM, EXTRCTR VLV		
24	86174500	43-810064	1	BACK-UP, 250DIA		
25	86189510	43-810062	1	O-RING, .144 ID .254 OD		
26	86189510	16-808190	1	SPRING, EXTRCTR VLV		
27	86273350	00-000306	2	SCR, 6-32 X 1 SCHD SS		
28	86194500	17-803033	1	TIP, SPRY 80015X1/8P SST		
29	86178540	58-500638	1	CSTG, TRIGGER CLMP		
30	86273360	00-000307	2	SCR, CAP 6-32X3/8 SOCHD		
31	86195210	52-501623	1	VALVE, UPHLST TL		
32	86195530	52-501626	1	VALVE, ADJ-UPHLST TL VLV		
33	86189460	43-810016	1	O-RING, 5/32IDX9/32OD VIT		
34	86182570	43-807513	1	GASKET, UPHLST TL VLV		
35	86183770	10-805348	1	HOSE, 3/16X6-1/2 (1/8P BS)		
36	86179740	13-806030	1	D SC, 1/8MX1/8FP SST		
37	86192070	00-000408	1	SCR, SET 3-32 X 1/4 SOCHD		
-	86178980	48-941164	1	DECAL, UPHLST TL		
-	86186160	66-808169	1	KIT, REPAIR-WAND VLV		INCLUDES PARTS 20-22 & 24-26

# Shelf Assembly - Optional

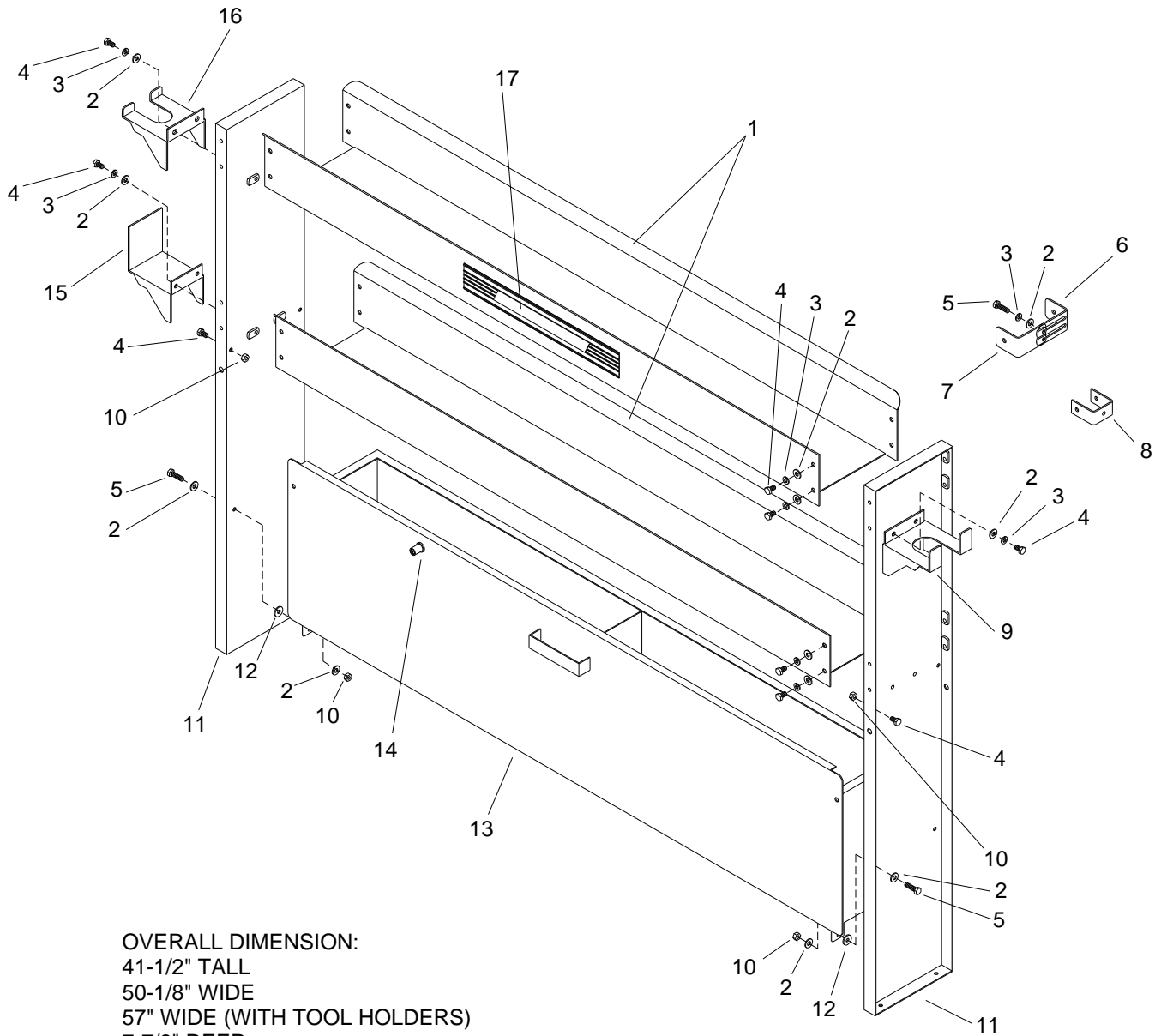

OVERALL DIMENSION:  
 41-1/2" TALL  
 50-1/8" WIDE  
 57" WIDE (WITH TOOL HOLDERS)  
 7-7/8" DEEP

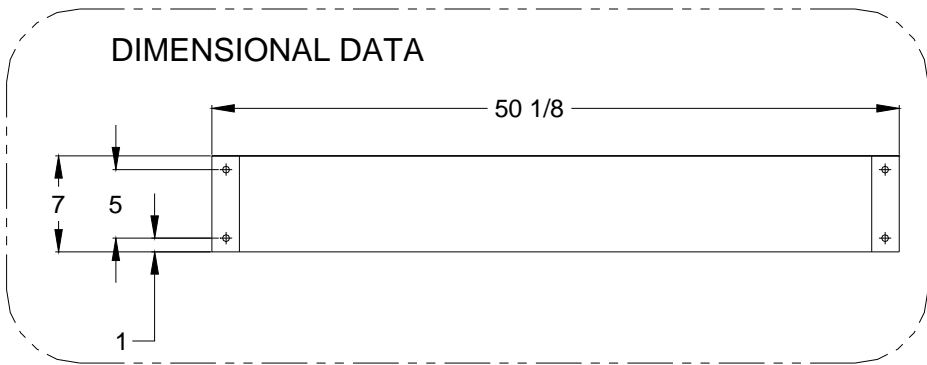

REF	PART NO.	PRV NO.	QTY	DESCRIPTION	SERIAL NO. FROM	NOTES:
-	86285410	65-950392	1	VAN STORAGE UNIT		COMPLETE
1	86192680	56-501921	1	SHELF, LWR		
2	86270330	02-000066	20	FLATWASHER, 1/4		
3	86010780	87162	20	WASHER, 1/4 SPLIT LOCK		
4	86274760	70271	20	SCR, 1/4-20 X 1/2 HHCS PLTD		
5	86274750	70270	4	SCR, 1/4-20 X 3/4 HHCS PLTD		
6	86175710	50-501840	1	BRKT, ADJUST MTG SLOT		
7	86175730	56-502067	1	BRKT, ADJUST MTF HLDR		
8	86198090	56-501942	1	BRKT, SHELF MOUNTING		
9	86285120	41460	1	HOLDER, STAIR TOOL		
10	86270620	01-000105	4	LOCK NUT, 1/4-20 HXHD		
11	86024890	56-501922	2	PANEL, SHLF END		
12	86278840	50-501749	2	WASHER, NYLON		
13	86021920	56-501920	1	DRAWER, SHELF GRAY		
14	86186850	46-802506	1	LATCH, ADJ GRIP		
15	86183180	50-501755	1	HOLDER, UP TL HOSE		
16	86183170	50-501754	1	HOLDER, UPHST TL		
17	86179350	48-941152	1	DECAL, PROCHEM		
-	86162440	66-945424	1	KIT, ADJ BRKT.		INCLUDES PARTS 6,7 & MOUNTING HARDWARE

# Auxiliary Water Tank with Pump - Optional

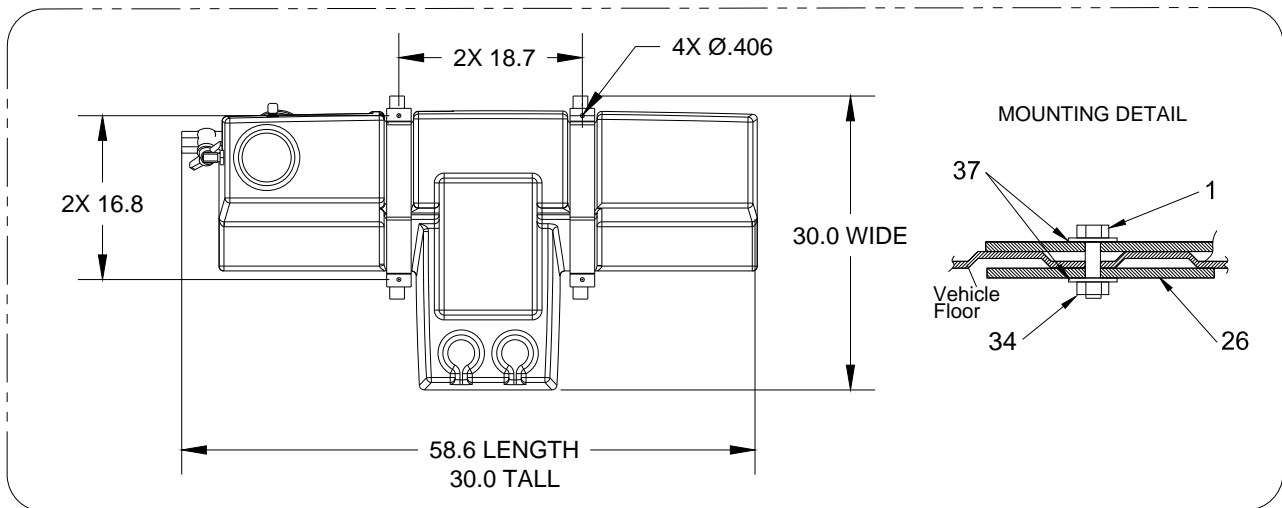
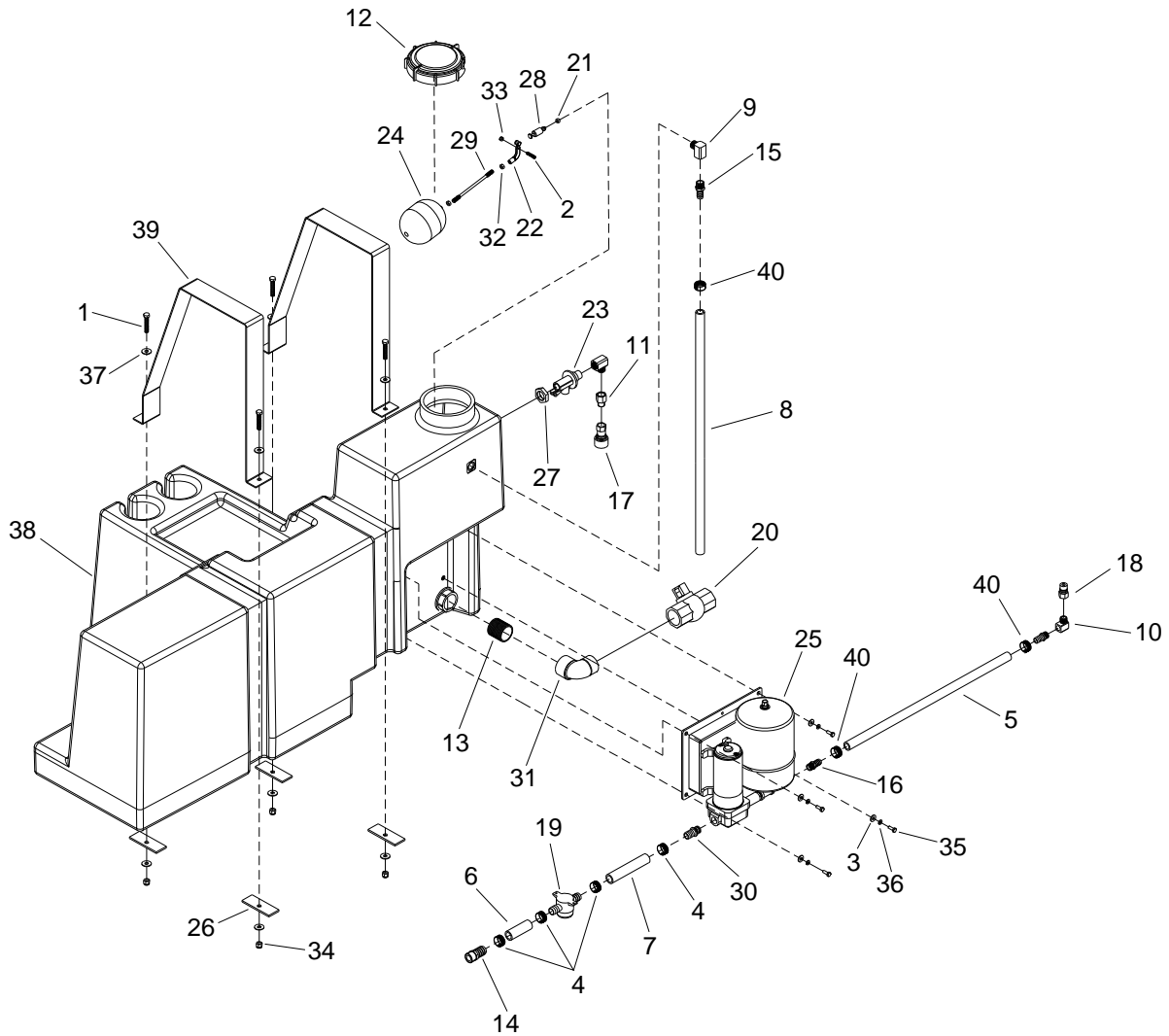

*Auxiliary Water Tank with Pump - Optional*

REF	PART NO.	PRV NO.	QTY	DESCRIPTION	SERIAL NO. FROM	NOTES:
1	86277830	00-000072	4	SCR, 3/8-16 X 2" HXHD		
2	86277850	00-000337	1	SCR, 10-32 X 1" SOCHD SST		
3	86270330	02-000066	4	FLATWASHER, 1/4		
4	86177020	03-000113	4	CLAMP, HOSE #12 SST		
5	86280550	09-805446	1	HOSE, 5/8 ID BLU X 55"		
6	86280290	09-805278	1	HOSE, 3/4 ID WTR X 3"		
7	86280420	09-805357	1	HOSE, 3/4 ID WTR X5.5"		
8	86280140	09-805406	1	HOSE, 5/8 ID BLU X 30 1/2		
9	86180170	11-800041	2	ELL, STREET 1/2 BR MACH		
10	86180210	11-800275	1	ELL, ST 3/8 BR		
11	86191600	11-800283	1	RED, 1/2FP X 3/8P BR		
12	86176400	11-800432	1	CAP, WATER BOX		
13	86188470	11-800524	1	NIP, 1-1/2XCL PVC (SCH80)		
14	86181320	12-800095	1	FTTG, BRB 3/4PX3/4H BR		
15	86181360	12-800269	1	FTTG, BRB 1/2 X 5/8H BR		
16	86181400	12-800345	2	FTTG, BRB 3/8P X 5/8 BR		
17	86179710	13-806008	1	DISCONNECT 3/8F X 3/8FP		
18	86179630	13-806009	1	DISCONNECT 3/8M X 3/8FP		
19	86180900	14-806553	1	FILTER, DEMAND PUMP		
20	86195010	15-808080	1	VALVE, BALL PVC 1-1/2FP		
21	86192380	16-808164	1	SEAT, FLOAT VLV TM		
22	86173820	16-808216	1	ARM, PIVOT-FH VLV		
23	86174610	16-808217	1	BDY, FLOAT VLV		
24	86174540	19-807014	1	BALL, FLOAT		
25	86190740	41-905049	1	PMP, WTR BOOSTER FLOJET 2		
26	86190170	50-500511	4	PLATE, INSTALL MT		
27	86189010	52-501706	1	NUT, FLOAT VALVE		
28	86028860	52-800314	1	PISTON, FLOAT VLV PISTON		
29	86181150	54-501715	1	FLOAT ROD, TM		
30	86186120	48-809423	1	KIT, PORT DEMAND PUMP		
31	86180010	31100	1	ELBOW, 1.5 STREET PVC MP X FP		
32	86270770	57006	2	NUT, 1/4-20 HEX		
33	86270990	57090	1	NUT, 10-32 HEX NYLOCK SS		
34	86005770	57119	4	NUT, 3/8-16 HEX NYLOCK		
35	86274750	70270	4	SCR, 1/4-20 X 3/4 HHCS PLTD		
36	86010780	87162	4	WASHER, 1/4 SPLIT LOCK PLTD		
37	86279510	87171	8	WASHER, 3/8 FLAT		
38	86031000	790617	1	TANK, FRESH WATER 70GAL		
39	86057170	790666	2	STRAP, WTR TNK HOLD DOWN		
40	86177060	03-000246	3	CLAMP, HOSE #8 SST		

# Water Tank Dual with Demand Pump - Optional

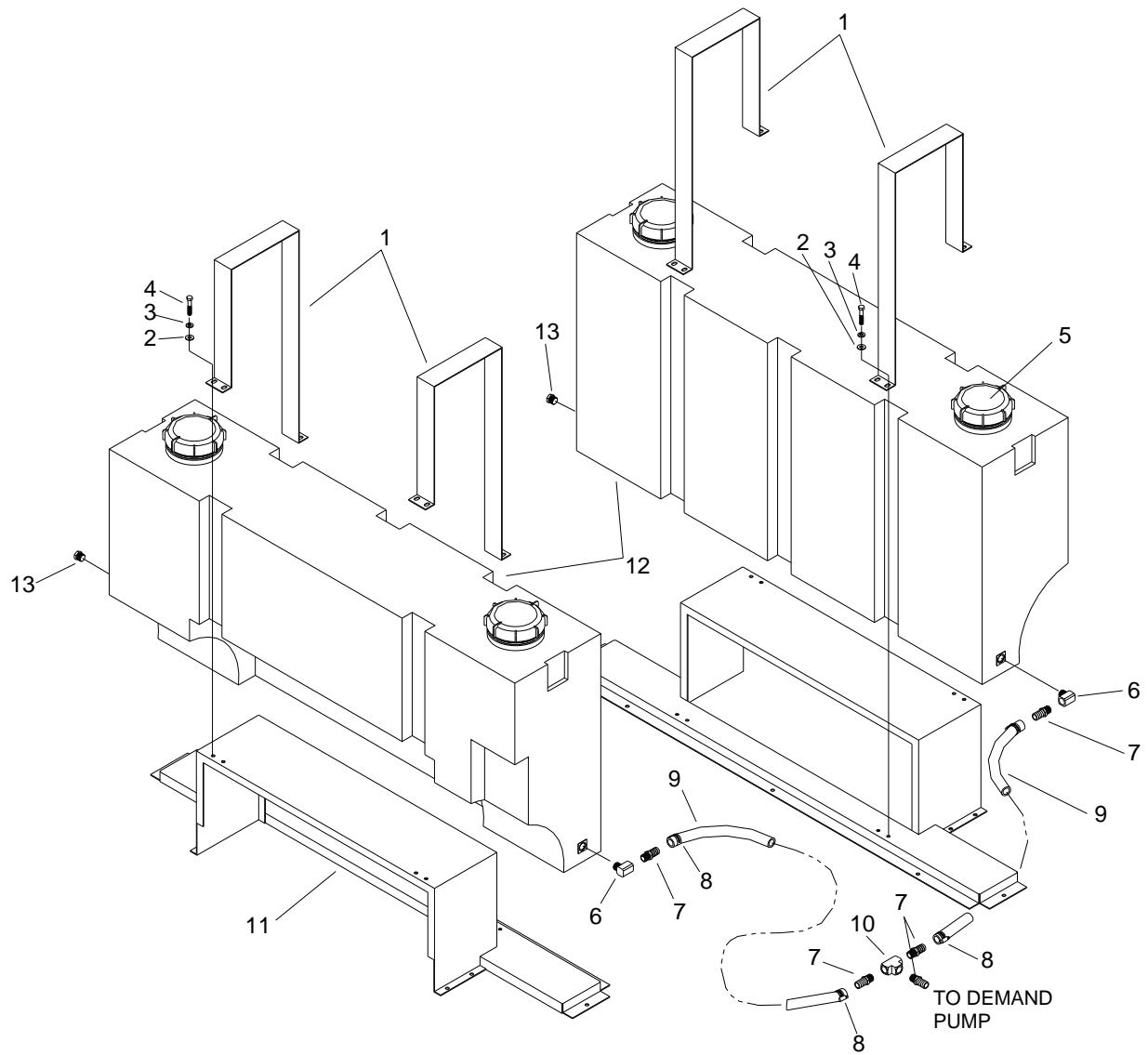

OVERALL DIMENSION:  
 32-1/2" TALL  
 62-5/8" WIDE  
 15-1/2" DEEP

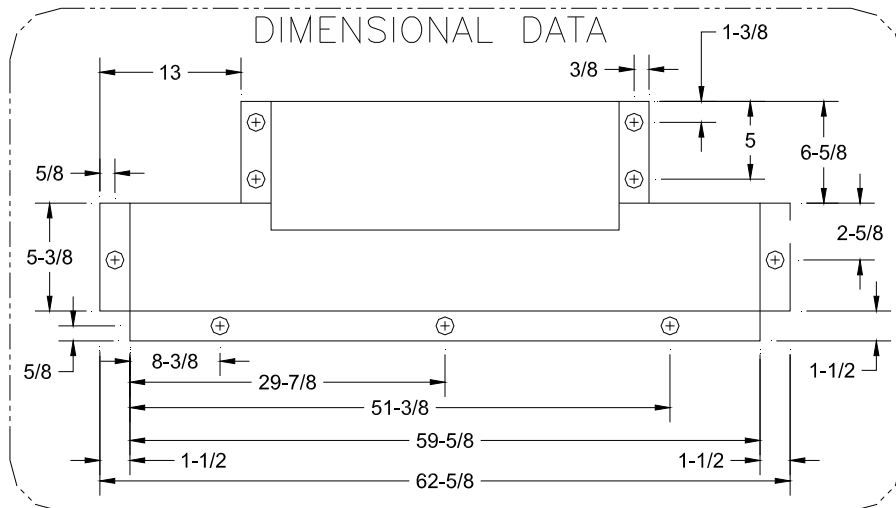
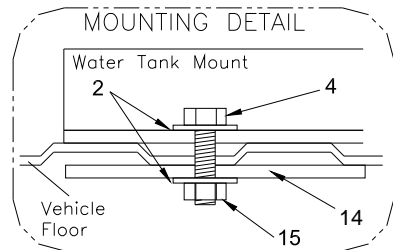



*Water Tank Dual with Demand Pump - Optional*

REF	PART NO.	PRV NO.	QTY	DESCRIPTION	SERIAL NO. FROM	NOTES:
-	86041730	66-945260	-	TANK, DUAL SADDLE W/DMD PUMP		COMPLETE
-	86041710	66-945265	-	SINGLE SADDLE TANK W/DMND PMP		COMPLETE
1	86048310	50-501774	4	HOLD DOWN, SADDLE TANK GRAY		
2	86279510	87171	16	WASHER, 3/8 FLAT		
3	86010790	87163	16	WASHER 3/8 SPLIT LOCK		
4	86277830	00-000072	16	SCR, 3/8-16 X 2' HXHD		
5	86176400	11-800432	4	CAP, WATER BOX		
6	86180170	11-800041	2	ELL, STREET 1/2 BR		
7	86181370	12-800278	4	FTTG, BRB 1/2P X 3/4H BR		
8	86177020	03-000113	4	CLAMP, HOSE #12 SST		
9	86280590	09-805456	1	HOSE, WTR 3/4 X 96		
10	86194120	11-800085	1	TEE, 1/2 BRASS		
11	86043320	56-502000	2	ASSY, BASE SADDLE TANK GRAY		
12	86030990	58-500661	2	MOLDING, WATER TANK		
13	86190500	11-800168	2	PLUG, 1/2 BRASS HXHD		
14	86190170	50-500511	1	PLATE, INSTALL MT		
15	86005770	57119	9	NUT, 3/8-16 HEX NYLOCK		
-	86285190	41458	1	SHLR, CHEM, 10-GAL JUG		

# Water Tank - Demand Pump - Optional

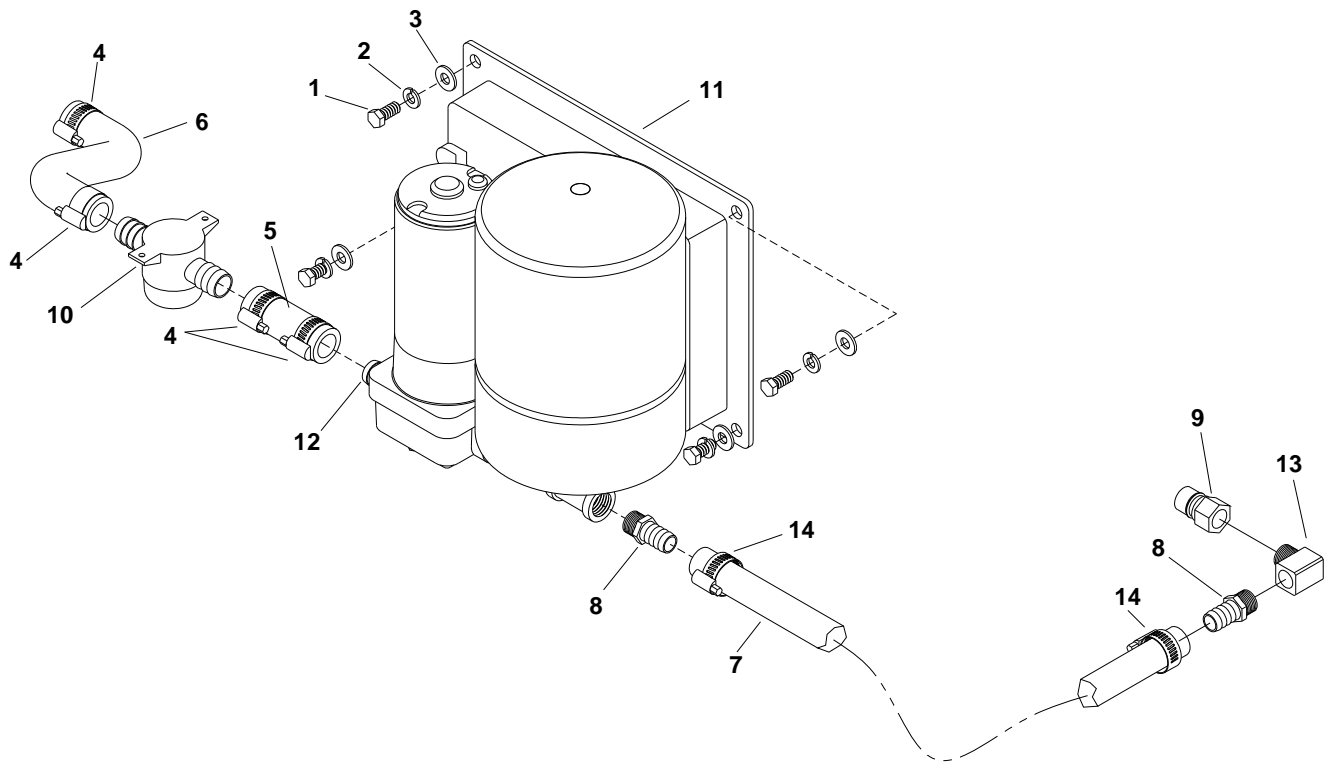

REF	PART NO.	PRV NO.	QTY	DESCRIPTION	SERIAL NO. FROM	NOTES:
1	86006760	70305	4	SCR, 5/16-18 X 3/4 HHCS GR5 PL TDL		
2	86279130	87083	4	WASHER, 5/16 SPLIT LOCK PLTD		
3	86278830	02-000143	4	WASHER, 5/16 FLAT		
4	86177020	03-000113	4	CLAMP, HOSE #12 SST		
5	86280290	09-805278	1	HOSE, WATER 3/4 X 3"		
6	86280420	09-805357	1	HOSE, WATER .75 X 5.5		
7	86280550	09-805446	1	HOSE, 5/8ID BLU X 55"		
8	86181400	12-800345	1	FTTG, BRB 3/8P X 5/8H BR		
9	86179630	13-806009	1	DISCONNECT, 3/8M X 3/8FP		
10	86180900	14-806553	1	FILTER, DEMAND PUMP		
11	86190740	41-905049	1	PUMP, WATER BOOSTER		
12	86186120	48-809423	1	KIT, PORT		
13	86180210	11-800275	1	ELBOW, ST 3/8 BR		
14	86177060	03-000246	2	CLAMP, HOSE #8 SST		
-	86191390	65240	1	PUMP ONLY, TM DEMAND		
-	86186030	47449	1	KIT SERVICE DEMAND PMP		

# Auxiliary Water Tank - Optional

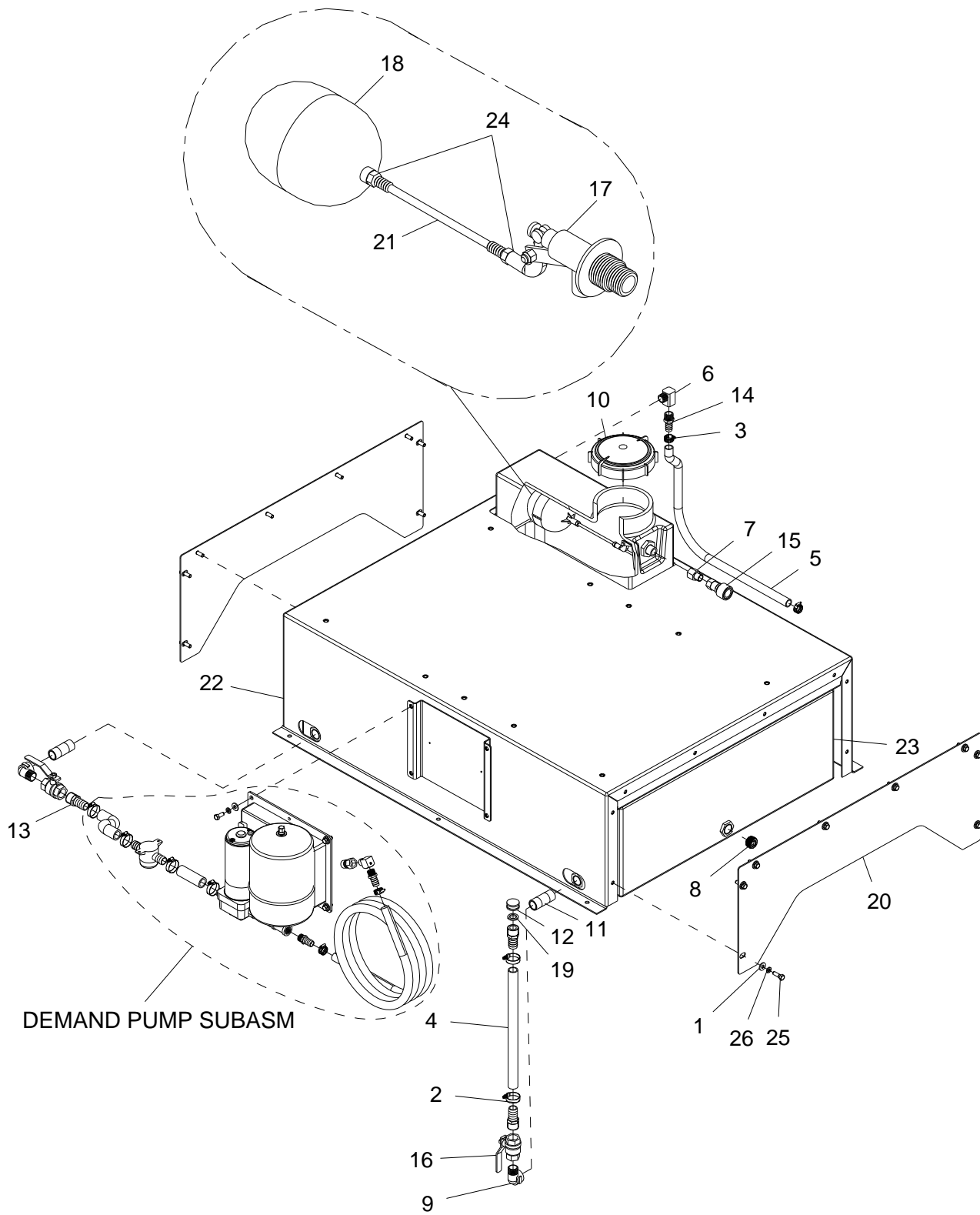

REF	PART NO.	PRV NO.	QTY	DESCRIPTION	SERIAL NO. FROM	NOTES:
1	86278830	02-000143	20	WASHER, 5/16 FLAT PLTD		
2	86177020	03-000113	6	CLAMP, HOSE #12 SST		
3	86177060	03-000246	4	CLAMP, HOSE, #8 SST		
4	86280060	09-805100	1	HOS, 3/4ID WTR X 13.5"		
5	86280100	09-805288	1	HOS, 5/8ID BLU X 27		
6	86180170	11-800041	1	ELL, STREET 1/2 BR MACH		
7	86191600	11-800283	1	RED, 1/2FP X 3/8P BR		
8	86190190	11-800357	1	PLG, 3/4 SOCHD BR		
9	86180260	11-800401	2	ELL, 3/4 ST BR		
10	86176400	11-800432	1	CAP, WATER BOX		
11	86188480	11-800525	2	NIP,3/4 X 2-1/2 BR		
12	86176420	12-800052	1	CAP, HOS 3/4 BR		
13	86181320	12-800095	3	FTTG, BRB 3/8P X 3/4H BR		
14	86181360	12-800269	1	FTTG, BRB 1/2P X 5/8H BR		
15	86179710	13-806008	1	DSC, 3/8F X 3/8FP		
16	86195330	15-808072	2	VLV, BALL 3/4 BS		
17	86195060	15-808110	1	VALVE, FLOAT, TM		
18	86174540	19-807014	1	BALL, FLOAT		
19	86195820	43-807008	1	WSR, HOS 5/8ID 1"OD		
20	86050960	50-502092	2	PL, FRT TANK SUPPORT		
21	86181150	54-501715	1	ROD, FLOAT 1/4-20 X 6" SS		
22	86047580	56-502505	1	ENCL, TNK SUPT W/DEM PMP		
23	86030970	58-500899	1	MLDG, WTR TNK, 60G W/OVRFI		
24	86270770	57006	2	NUT, 1/4-20 HEX		
25	86006750	70302	16	SCR, 5/16-18 X 1.00 HHCS GR5		
26	86279130	87083	20	WASHER, 5/16 SPLIT		

# Hose Reel - Optional

## DIMENSIONAL DATA

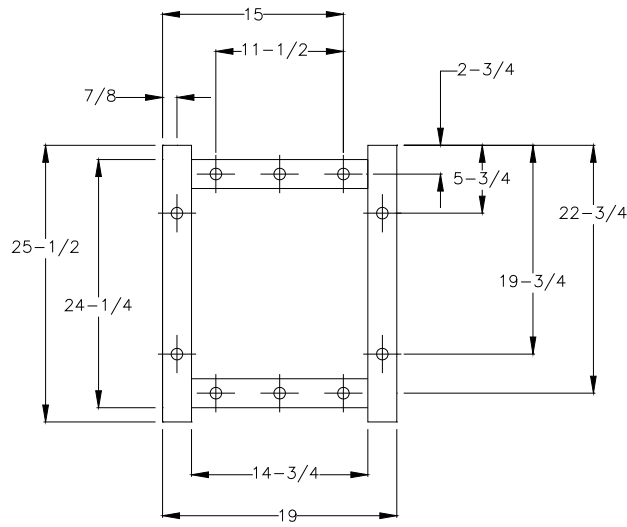
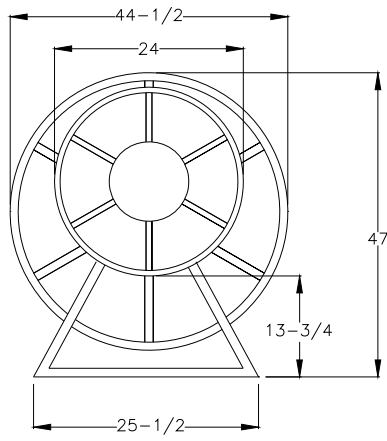

## MOUNTING DETAIL

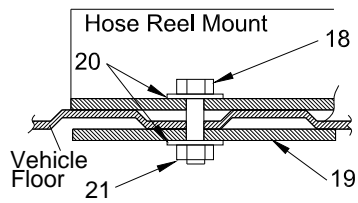

OVERALL DIMENSIONS:  
47" TALL  
29" WIDE  
44-1/2" DEEP

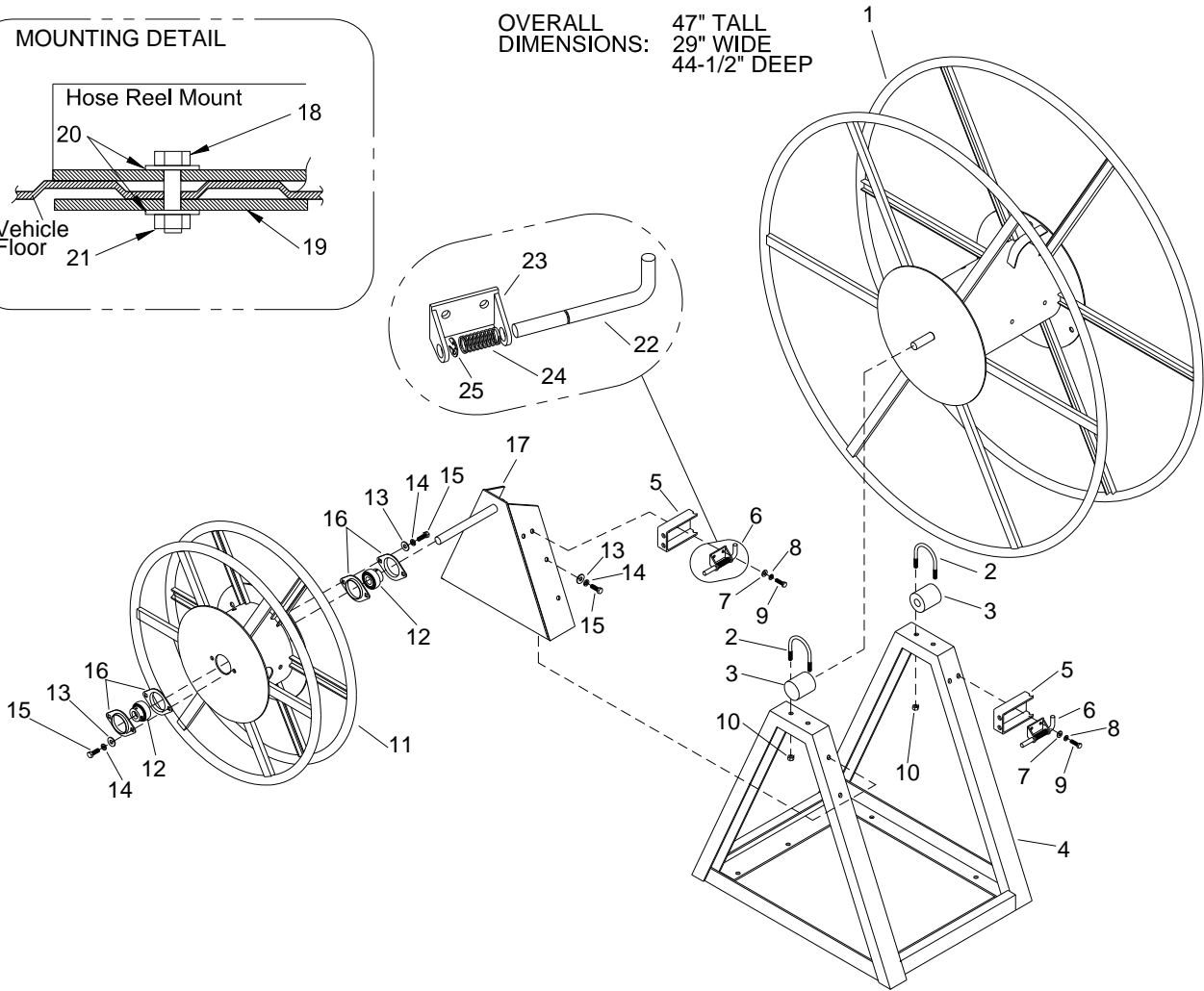

REF	PART NO.	PRV NO.	QTY	DESCRIPTION	SERIAL NO. FROM	NOTES:
1	86191620	56-501962	1	REEL, VACUUM HOSE GRAY		
2	86177270	03-000124	2	CLAMP, MFLR 1-3/4		
3	86175990	52-501685	2	BUSHING, HOSE REEL		
4	86174560	56-501960	1	BASE, HOSE RL (250')		
5	86175740	56-502207	1	BRKT, LOCKOUT HOSE REEL		
6	86186870	61-950854	1	LATCH ASSEMBLY		
7	86270330	02-000066	2	FLATWASHER, 1/4		
8	86010780	87162	2	WASHER, 1/4 SLPIT LOCK		
9	86274750	70270	2	SCR, 1/4-20 X 3/4 HHCS PLTD		
10	86005650	57031	2	NUT, 5/16-18 HEX		
11	86191820	56-501968	1	REEL, HP HOSE GRAY		
12	86174740	45-802138	2	BEARING HOSE REEL		
13	86278830	02-000143	4	FLATWASHER, 5/16		
14	86279130	87083	4	WASHER, 5/16 SPLIT LOCK PLTD		
15	86006750	70302	4	SCR, 5/16-18 X 1" HHCSGR5PLT		
16	86181030	44-802122	4	FLANGE, 47MST		
17	86174730	56-501961	1	BODY, HP HOSE GRAY		
18	86277830	00-000072	10	SCR, 3/8-16 X 2" HXHD		
19	86190170	50-500511	1	PLATE, INSTALL MT		
20	86279510	87171	10	WASHER, 3/8 FLAT		
21	86005770	57119	10	NUT, 3/8-16 HEX NYLOCK		
22	86189850	55-501789	1	PIN, LOCK HOSE REEL		
23	86175700	50-501812	1	BRKT, HOSE REEL LOCK		
24	86193240	04-000302	1	SPRING, LOCK-LOCK PIN ASSY		
25	86177190	04-000303	1	CLIP, RETAINER-LOCK PIN ASSY		

# Hose Diagram

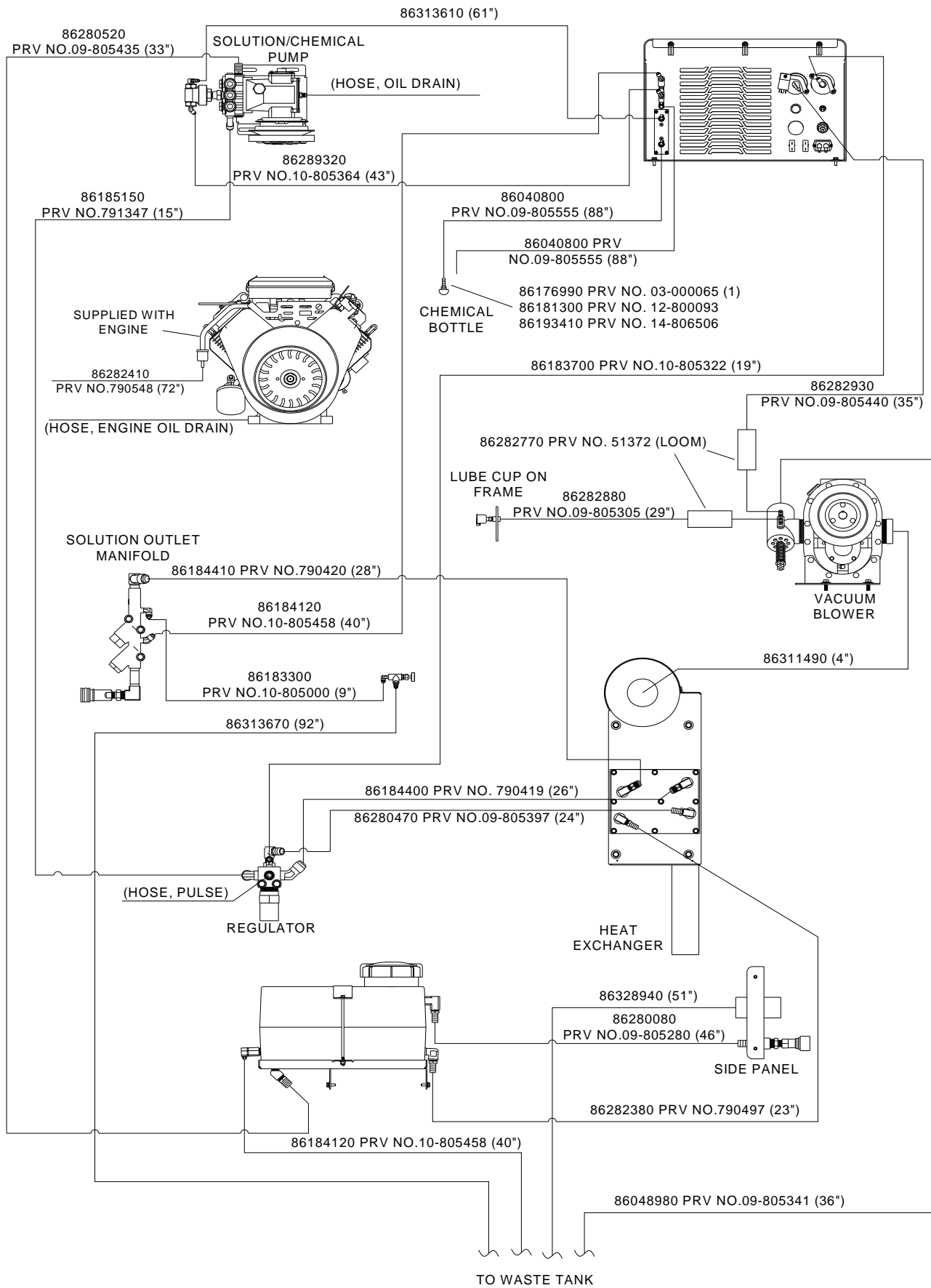



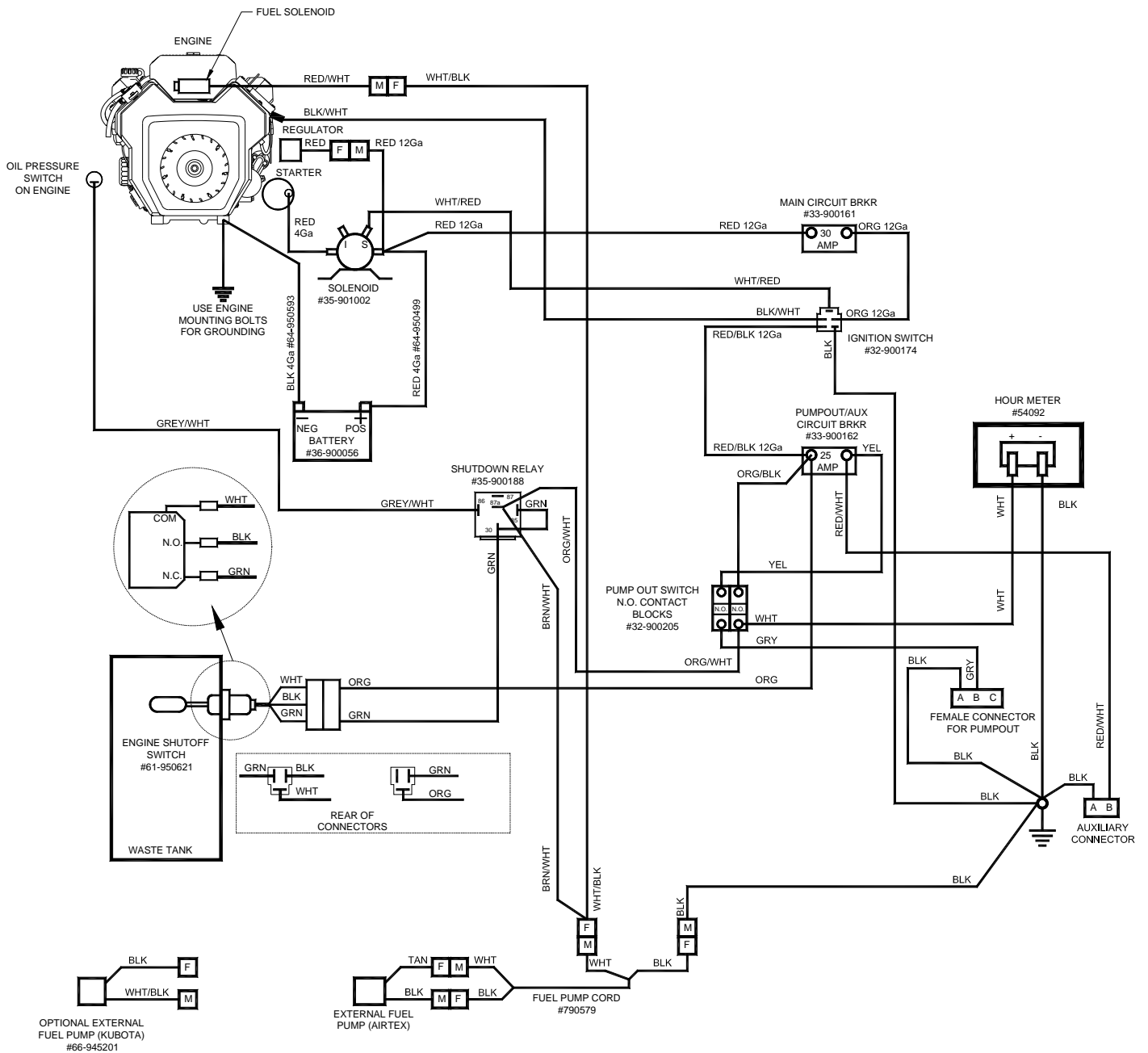

DO NOT GROUND FUEL PUMP TO MOUNTING BOX OR CHASSIS OF VAN  
USE SUPPLIED FUEL PUMP CORD ONLY